

Reinventing
flow.

Since 1964

NHM

Normal-Priming Centrifugal Pumps
Made of PVDF or PP with Magnetic Coupling

Neolution®



The Neolution® in Pump Efficiency.

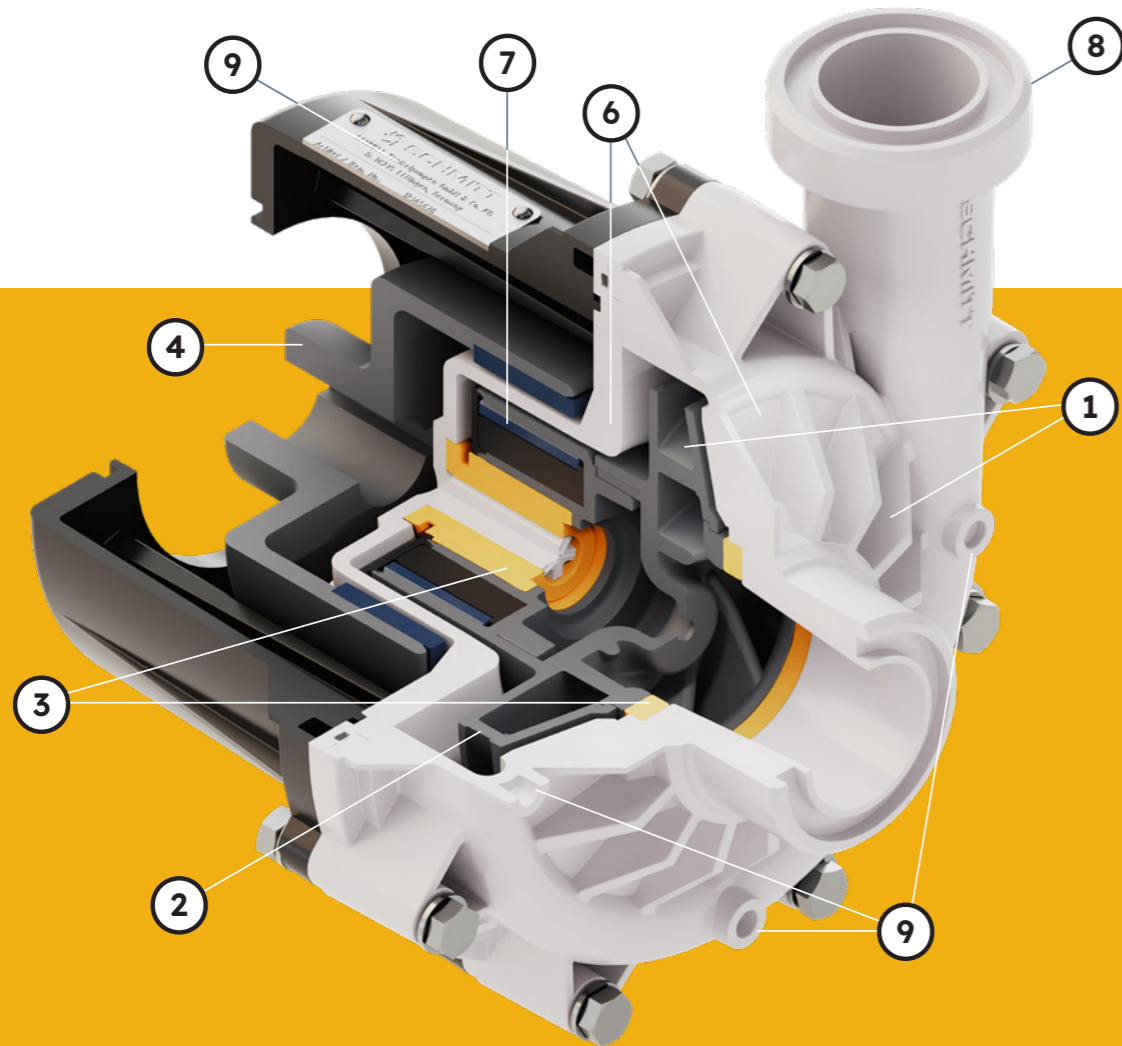

flow
reinvented!

- 1** Optimised pump hydraulics for best-in-class efficiencies of up to 76 %
- 2** Modular impeller design for easy replacement and cost-effective maintenance
- 3** Advanced slide bearing solution made from high-performance materials—durable and low-maintenance even under extreme operating conditions
- 4** Lantern bracket made of chemically resistant, carbon fiber-reinforced composite for high strength and corrosion resistance, even in aggressive environments
- 5** Chemically resistant type plate for reliable identification, even after years of operation in harsh environments
- 6** Simulation-optimized pump casing for reliable performance at high pressures and temperatures
- 7** High-performance neodymium magnets for secure torque transmission, even with high-density media
- 8** Available with threaded or flanged connections
- 9** Optional drain and vent ports for flexible installation configurations

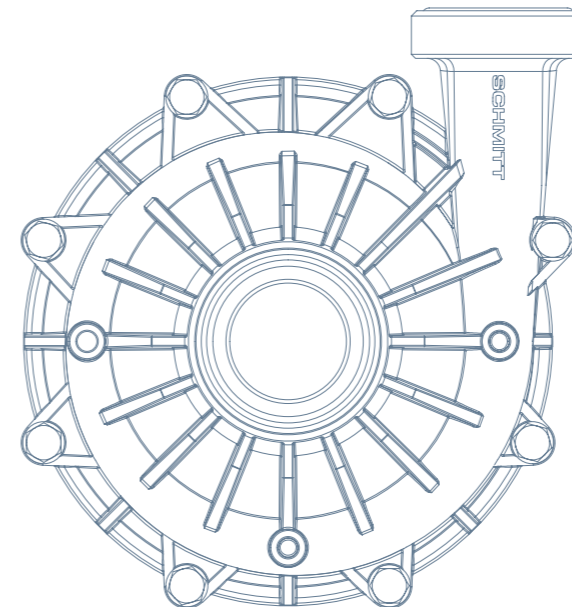

Normal-Priming Centrifugal Pumps

Made of PVDF or PP with Magnetic Coupling

Housing and impeller materials PVDF, PP

Elastomers EPDM, FKM (e.g. Viton®), FEP, FFKM (e.g. Kalrez®)

Bearing material pairing SiC / SiC

The NHM achieves efficiency rates of up to 76 % thanks to its optimized hydraulic design, setting new standards for energy efficiency in its class. Manufactured from individually selectable, chemical-resistant high-performance materials, the NHM delivers exceptional performance combined with outstanding durability.

Performance Overview

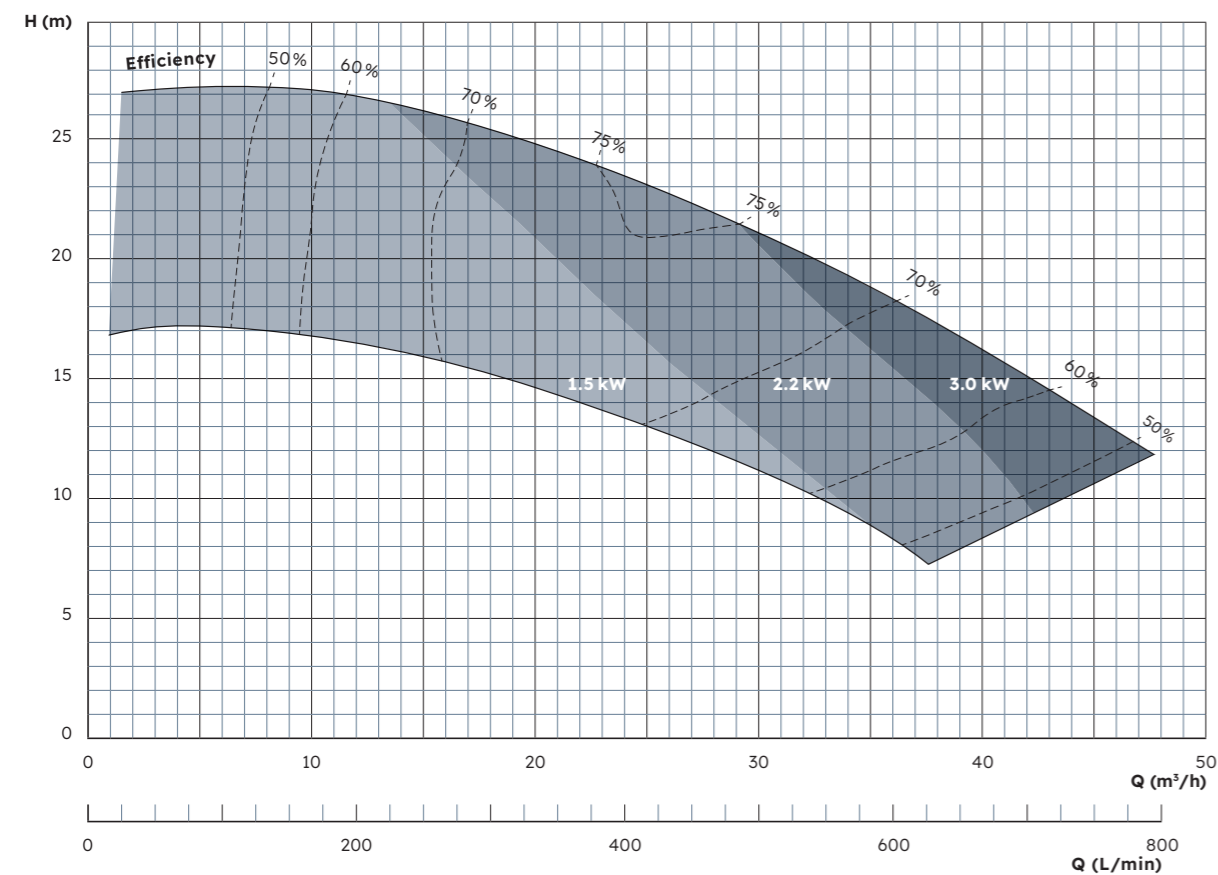

Advantages

- + Best-in-class efficiency and outstanding energy performance
- + Wear-resistant and maintenance-free design thanks to the unique bearing system with slide-axis technology
- + Hermetically sealed, contact-free magnetic drive – eliminating the need for a mechanical seal

All sizes are available in ATEX-certified versions for use in ATEX Zones 1 and 2. Available with threaded or flanged connections, as well as optional drain and vent ports.

Up to 76 % efficiency

Advanced Schmitt hydraulic design.

Maximum energy savings

Depending on the operating point, energy consumption can be reduced by up to 50 % compared to the previous generation



Description

Characteristics

Chemical-resistant, single-stage plastic centrifugal pump with close-coupled design, with magnetic coupling, normal-priming

Features

- Hermetically sealed and absolutely leak-free (no mechanical seal)
- Contactless magnetic drive with high-performance neodymium magnets
- Highly efficient impeller and optimised volute casing for efficiencies of up to 76 %
- Modular impeller and internal magnet for easy replacement
- Maintenance-free in normal operation due to extra-large slide bearings
- Reliable operation even at high pressures and temperatures thanks to unique backplate geometry
- All wetted parts made of high-quality, corrosion-resistant plastics (natural PVDF or PP-CF and natural PP)
- Equipped as standard with threaded connections in accordance with ISO 228-1 or flange connections
- Universally applicable, low-noise, and compact
- Optional approval for use in potentially explosive atmospheres (ATEX Zones 1 and 2)
- Conductive plastic parts available for ATEX Zone 1 (on request)
- All screws made of V4A stainless steel (1.4571)
- Optional ventilation or drainage holes for individual installation positions

Fields of application

Pumping of acids, bases, lye, or other corrosive, harmful, or toxic liquids in applications where leakage of even small quantities is undesirable and a hermetically sealed pump is required.

Delivery of highly pure and sensitive liquids where contamination must absolutely be avoided.

For example in the following applications:

- Electroplating and surface coating
- Wet chemical processes in semiconductor technology, solar cell production, and PCB manufacturing
- Wastewater and fresh water treatment
- Laboratory equipment and medical technology
- Environmental technology, emission control, gas scrubbers
- Battery production and energy storage
- High-purity applications, demineralised water, ultrapure water

Characteristics

Available materials

- Pump housing: PVDF, PP
- Elastomers: FKM, EPDM, FEP, FFKM
- Bearing material pairing: SiC / SiC

Standard motors (available from stock)

- Three-phase motors: Δ 230/Y400 V, 3-ph @ 50 Hz; Y480 V, 3-ph @ 60 Hz; IP55, Class F, with PTC as standard
- All three-phase motors from 0.75 kW comply with energy efficiency class IE3
- Single-phase motors: up to 1.1 kW: 230 V, 1-ph, 50/60 Hz, IP55, Class F
- ATEX-certified motors (temperature rating T3)

Special motors (on request)

- Special voltages and frequencies
- Three-phase motors with integrated frequency converter
- ATEX-certified motors with flameproof enclosure and temperature rating T4
- Four-pole motors with 1450 rpm @ 50 Hz / 1650 rpm @ 60 Hz
- UL- and CSA-certified motors
- Special types of protection, e.g., IP65
- Special insulation classes, e.g., tropical insulation
- Multi-voltage, e.g., Δ 220-290/Y380-500 V @ 50 Hz; Δ 220-332/Y380-575 V @ 60 Hz
- Direct-current motors (DC or BLDC)

Operating conditions

- Flow rate up to 42 m³/h
- Maximum head up to 27 m
- Liquid temperature: -5°C to 95°C (PVDF); 0°C to 80°C (PP)
- Ambient temperature: -10°C to 40°C, higher temperatures on request
- Can be adapted to high-density liquids (up to 2.0)

Performance Curves NHM200 (1,5 kW, 2,2 kW or 3,0 kW)

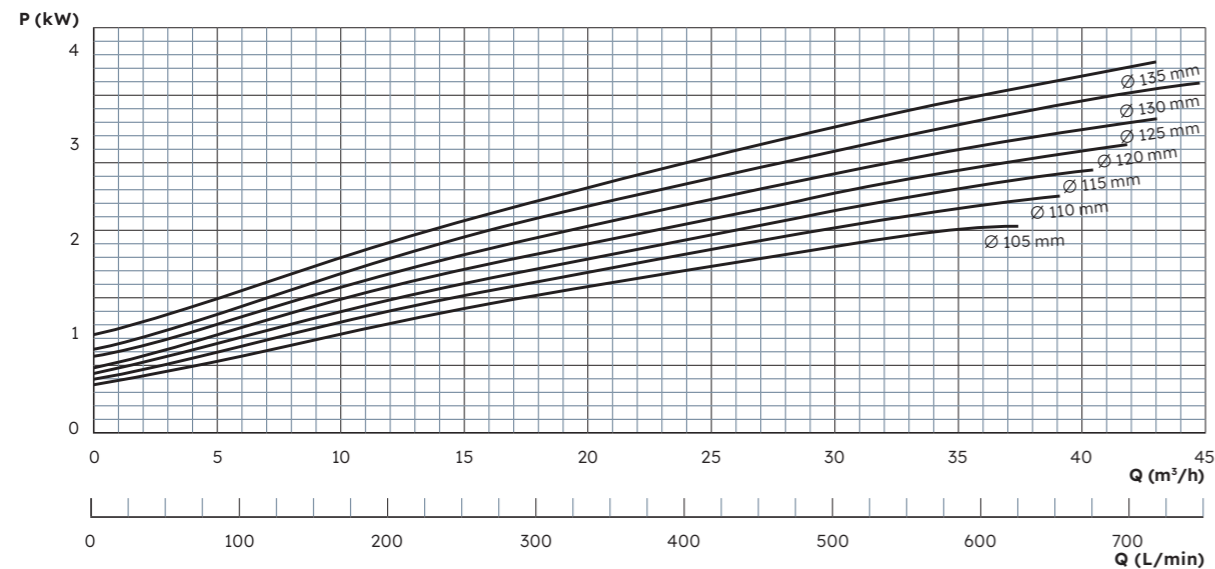
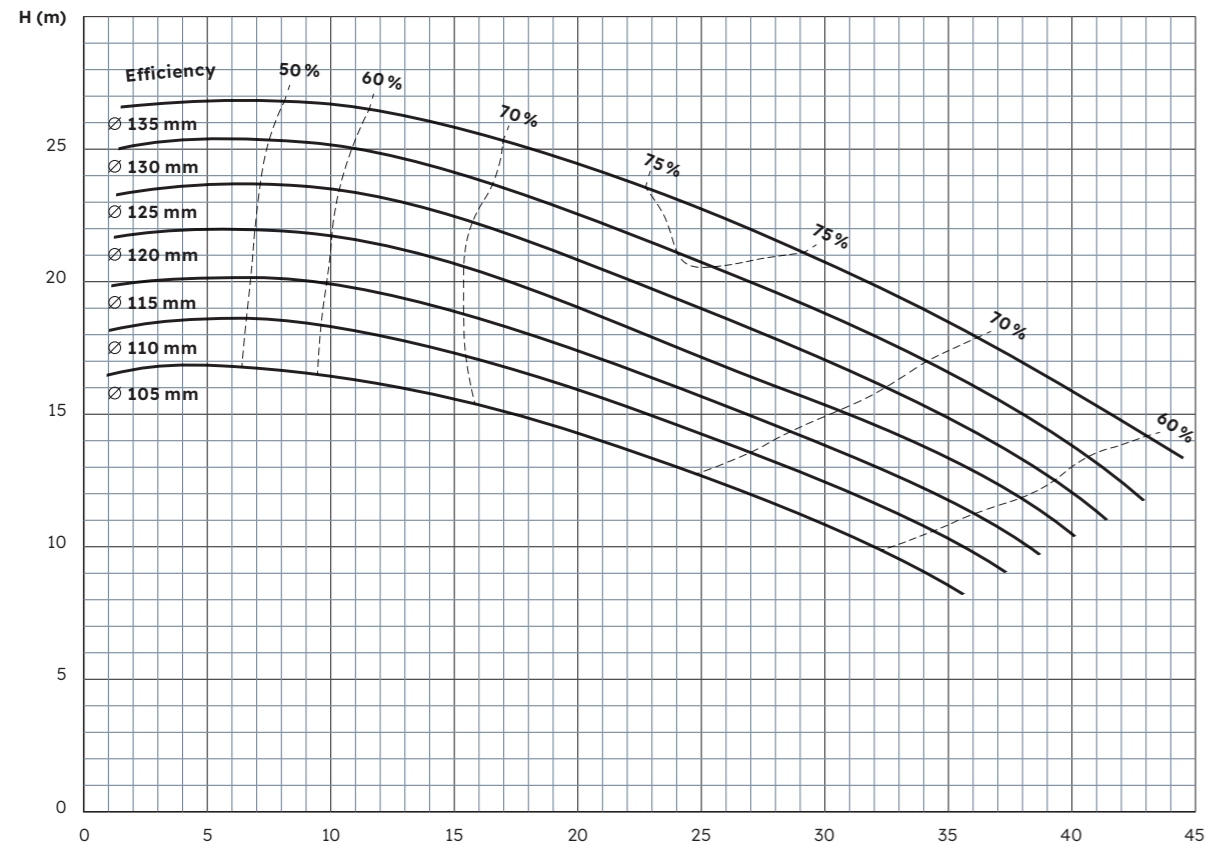

Neolution®

Efficiency

The development of Neolution® technology embodies our full engineering expertise and more than 60 years of experience.

With efficiencies of up to 76%, it sets a new benchmark—both within our product portfolio and across the market.

Energy Efficiency

The reduction of energy consumption and associated CO₂ emissions is a fundamental requirement for suppliers of industrial equipment.

Depending on the operating point, Neolution pumps achieve energy savings of up to 50% compared to the previous generation, delivering a measurable increase in overall process efficiency.

Corrosion Resistance

Neolution pumps meet the same chemical resistance requirements as our other pump series.

Material selection and design are engineered for use with a wide range of media, including chemically demanding applications.

Durability

A key factor in the performance of Neolution pumps is the newly developed bearing technology.

Its large, decoupled radial-axial slide bearings made of wear-resistant materials allow it to operate without requiring maintenance.

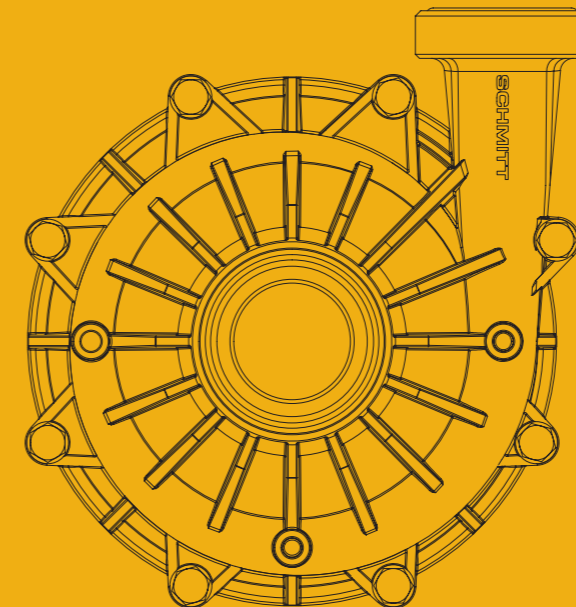

Dimensions

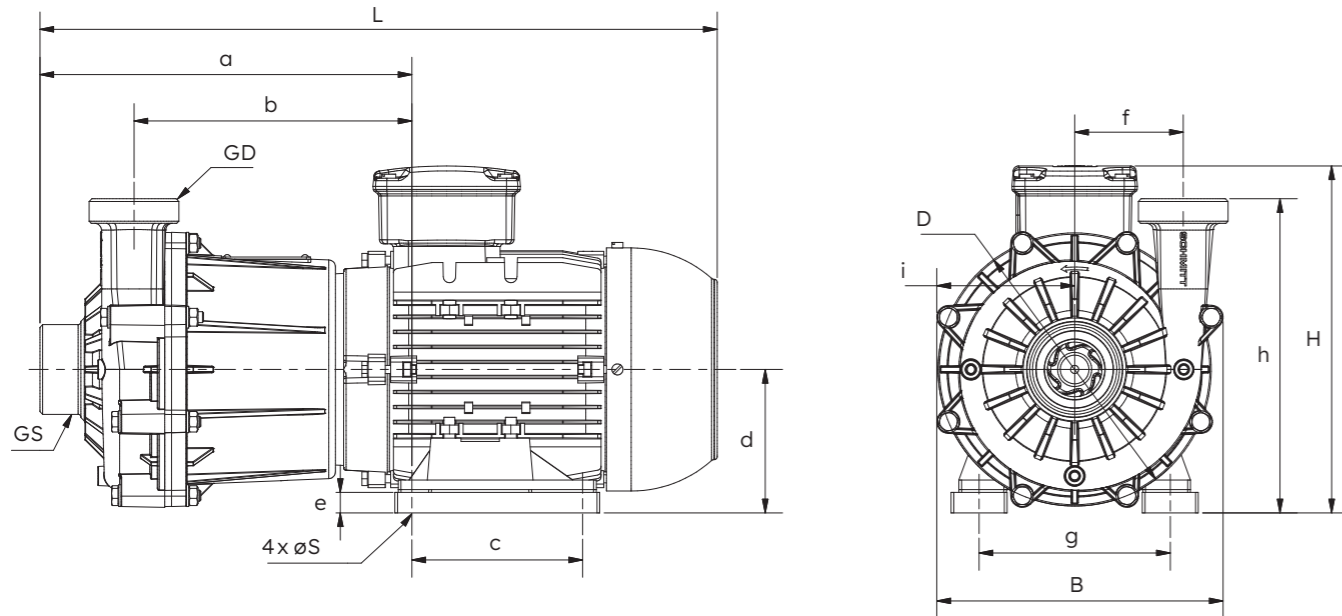

NHM 200	GS		GD		L (mm)	B (mm)	H (mm)	S (mm)	a (mm)	b (mm)	c (mm)	D (mm)	d (mm)	e (mm)	f (mm)	g (mm)	h (mm)	i (mm)	Weight (kg)
	ø Thread (in) (mm)	DN	ø Thread (in) (mm)	DN															
1.5 kW	G2 1/4" d50	40	G2 1/4" d50	40	496	210	254	10	272	203	125	200	105	15	80	140	230	101	25
2.2 kW	G2 1/4" d50	40	G2 1/4" d50	40	496	210	254	10	272	203	125	200	105	24	80	140	230	101	25
3.0 kW	G2 1/4" d50	40	G2 1/4" d50	40	532	282	264	12	279	211	140	200	105	14	80	160	230	101	35

All dimensions are provided for reference purposes only and are subject to change without notice. Dimensional variations may occur depending on motor type, manufacturer, or configuration. A certified dimensional drawing will be supplied with the official quotation or order confirmation.

Fittings

A comprehensive range of accessories is available for all Schmitt pumps, facilitating seamless integration into your system:

- + Flange adapters
- + Hose connectors
- + Weld-on fittings for stainless steel piping
- + Reducers and expanders
- + NPT-threaded adaptors
- + Inlet strainers for vertical pumps
- + Extension pipes for vertical pumps

Spare Parts

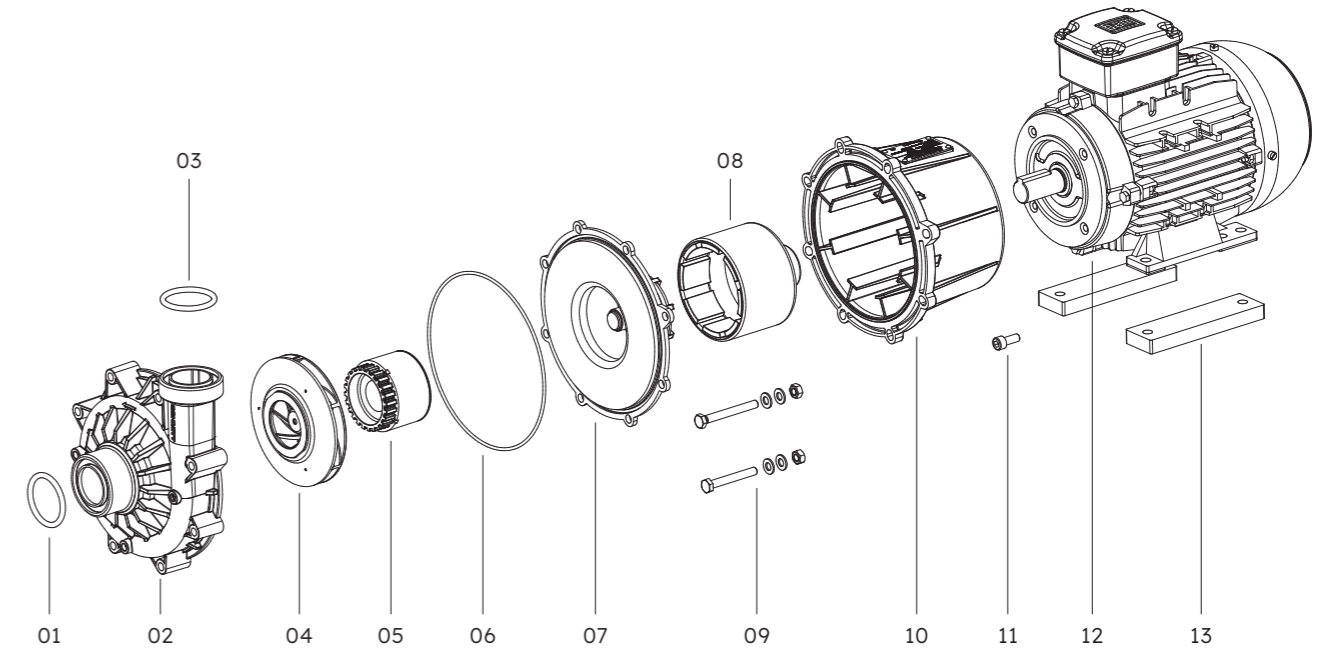

Position	Description	Available materials
01	O-ring (inlet port)	FKM, EPDM, FEP
02	Volute casing including bearing ring	Housing: PP-CF or PVDF Bearing ring: SiC
03	O-ring (outlet port)	FKM, EPDM, FEP
04	Impeller including bearing ring	Impeller: PP-CF or PVDF Bearing ring: SiC or carbon
05	Internal magnet including bearing sleeve	Internal magnet: PP, PVDF Bearing sleeve: SiC or carbon
06	O-ring (housing)	FKM, EPDM, FEP
07	Backplate including bearing bushing	Backplate: PP-CF or PVDF Bearing bushing: SiC
08	External magnet	
09	Screw set for housing	V4A
10	Enclosure	PP-CF
11	Screw set for enclosure	V4A
12	Motor	
13	Base plate	PP

SCHMITT

Reinventing flow. Since 1964

NHM

Normal-Priming Centrifugal Pumps
Made of PVDF or PP with Magnetic Coupling



SCHMITT

Reinventing flow. Since 1964

MPN

Normal-Priming Centrifugal Pumps
Made of PVDF or PP with Magnetic Coupling



SCHMITT

Reinventing flow. Since 1964

U

Normal-Priming Centrifugal Pumps
Made of PVDF or PP with Single Mechanical Seal



SCHMITT

Reinventing flow. Since 1964

T

Sealless Vertical Centrifugal Pumps
Made of PVDF or PP Dry-Run Safe



SCHMITT

Reinventing flow. Since 1964

UP | UP-DO

Normal-Priming Centrifugal Pumps
Made of Stainless Steel with Single or Double Mechanical Seal



SCHMITT

Reinventing flow. Since 1964

SMP

Self-Priming Centrifugal Pumps
Made of PP with Magnetic Coupling



SCHMITT

Reinventing flow. Since 1964

P

Normal-Priming Turbine Pumps
Made of PVDF or PP with Magnetic Coupling



SCHMITT

Reinventing flow. Since 1964

NEOCHEM BASE

Standardized Chemical Pumps
ETFE-lined with Magnetic Coupling



SCHMITT

Reinventing flow. Since 1964

NEOCHEM CORE

Heavy-Duty Standardized Chemical Pumps
FFA-lined with Magnetic Coupling



SCHMITT-Kreiselpumpen GmbH & Co. KG
Einsteinstrasse 33
76275 Ettlingen, Germany
T +49 7243 5453-0
F +49 7243 5453-22
sales@schmitt-pumpen.de
schmitt-pumpen.de

