

Series U, UP and UP-DO Centrifugal pumps with mechanical seal

Original operating manual

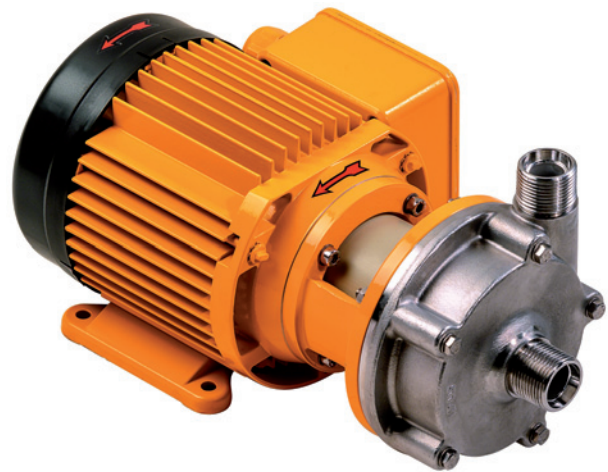

Version
Print-No. 11334/0923

SCHMITT-Kreiselpumpen GmbH & Co. KG
Einsteinstraße 33
76275 Ettlingen
Germany
Phone: + 49 (0) 7243 / 54 53 - 0
Fax: + 49 (0) 7243 / 54 53 - 22
E-mail: info@schmitt-pumpen.de
Internet: www.schmitt-pumpen.de

Subject to technical modifications.

Read carefully before use.
Save for future use.



Table of contents

1 About this document	5	5.4.4 Mounting the sealing liquid supply for the UP-DO	16
1.1 Target groups	5	5.4.5 Inspection for stress-free pipe connections	16
1.2 Other applicable documents	5	5.5 Electrical connection	16
1.3 Warnings and symbols	6	5.5.1 Connecting the motor	16
2 General safety instructions	7	5.5.2 Check direction of rotation	16
2.1 Intended use	7	6 Operation	17
2.2 General safety instructions	7	6.1 Preparing for commissioning	17
2.2.1 Product safety	7	6.1.1 Check downtimes	17
2.2.2 Obligations of the operating company	7	6.1.2 Prepare the sealing liquid supply for the UP-DO	17
2.2.3 Obligations of personnel	8	6.1.3 Filling and bleeding	17
2.3 Specific hazards	8	6.1.4 Check direction of rotation	17
2.3.1 Potentially explosive atmospheres	8	6.2 Commissioning	17
2.3.2 Electric shock	8	6.2.1 Switching on	17
2.3.3 Hazardous pumped media sprayed out	9	6.2.2 Switching off	17
2.3.4 Moving parts	9	6.3 Shutting down the pump	18
2.3.5 Hot surfaces	9	6.4 Restoring the pump to service	18
3 Layout and Function	10	6.5 Operating the stand-by pump	18
3.1 Marking	10	7 Maintenance	19
3.1.1 Name plate	10	7.1 Inspections	19
3.1.2 ATEX type plate	10	7.2 Servicing	19
3.2 Description	10	7.2.1 Maintenance in accordance with maintenance schedule	19
3.3 Assembly	11	7.2.2 Maintaining the mechanical seal and shaft sleeve	19
3.4 Mechanical seal	12	7.2.3 Cleaning the pump	20
4 Transport, Storage and Disposal	13	7.3 Dismounting	21
4.1 Transport	13	7.3.1 Preparations for dismounting	21
4.1.1 Unpacking and inspection on delivery	13	7.3.2 Dismount the pump	21
4.1.2 Lifting	13	7.4 Replacement parts and return	22
4.2 Storage	13	7.5 Installing	22
4.3 Disposal	13	7.5.1 Preparations for installation	22
5 Installation and connection	14	7.5.2 Installing the pump	22
5.1 Preparing for installation	14	7.5.3 Install the pump into the system	23
5.1.1 Check operating conditions	14	8 Troubleshooting	24
5.1.2 Preparing the installation site	14	9 Appendix	27
5.1.3 Prepare surface	14	9.1 Replacement parts	27
5.2 Setting up	14	9.1.1 Part numbers and designations	27
5.3 Planning pipelines	14	9.1.2 Drawings	28
5.3.1 Designing pipelines	14	9.2 Technical specifications	30
5.3.2 Arranging the supports and connections	14	9.2.1 Ambient conditions	30
5.3.3 Specifying nominal widths	14	9.2.2 Total pressure	30
5.3.4 Specifying pipe lengths	15	9.2.3 Shaft sleeve installation dimensions	30
5.3.5 Optimizing changes of cross section and direction	15	9.2.4 Sound pressure level	31
5.3.6 Providing safety and control devices (recommended)	15	9.2.5 Tightening torques of casing screws	31
5.4 Connecting the pipes	15	9.2.6 Flow rate	31
5.4.1 Keeping the piping clean	15	9.2.7 Cleaning agents	31
5.4.2 Installing suction pipe	15	9.2.8 Sealing liquid	31
5.4.3 Installing the pressure pipe	15	9.3 Maintenance schedule	32

9.4 Declaration of conformity in accordance with
EC machinery directive 33

List of figures

Fig. 1	Name plate (example)	10
Fig. 2	ATEX type plate (example)	10
Fig. 3	Layout of series U	11
Fig. 4	Layout of series UP	11
Fig. 5	Layout of series UP-DO	12
Fig. 6	Attach the lifting gear to the modular pump (illustration of general principle)	13
Fig. 7	Straight pipe lengths in front and after the pumps (recommended)	15
Fig. 8	Connection diagram for the sealing liquid supply	16
Fig. 9	Parts (sectional drawing)	28
Fig. 10	Parts (exploded drawing), example series U	29
Fig. 11	Shaft sleeve installation dimensions	30

List of tables

Tab. 1	Other application documents, purpose and where found	5
Tab. 2	Warning signs and consequences if disregarded	6
Tab. 3	Symbols and their meaning	6
Tab. 4	Measures to be taken if the pump is shut down	18
Tab. 5	Measures depending on the behavior of the pumped liquid	18
Tab. 6	Fault/number assignment	24
Tab. 7	Troubleshooting list	26
Tab. 8	Designation of components according to part numbers	27
Tab. 9	Ambient conditions	30
Tab. 10	Total pressure	30
Tab. 11	Installation dimensions	30
Tab. 12	Sound pressure level	31
Tab. 13	Tightening torques of casing screws	31
Tab. 14	Flow rate	31
Tab. 15	Characteristics of the sealing liquid	31
Tab. 16	Maintenance schedule	32

1 About this document

This manual:

- is an integral part of the pump
- applies to all series referred to
- describes safe and proper operation during all operating phases

1.1 Target groups

Operating company

- Responsibilities:
 - Always keep this manual accessible where the device is used on the system.
 - Ensure that employees read and observe this document, particularly the safety instructions and warnings, and the documents which also apply.
 - Observe any additional country-specific rules and regulations that relate to the system.

Qualified personnel, fitter





- Mechanics qualification:
 - Qualified employees with additional training for fitting the respective pipework
- Electrical qualification:
 - Qualified electrician
- Transport qualification:
 - Qualified transport specialist
- Responsibility:
 - Read, observe and follow this manual and the other applicable documents, especially all safety instructions and warnings.

1.2 Other applicable documents



Document/purpose	Where found
The following documents are available online: <ul style="list-style-type: none"> • ATEX additional instructions • Resistance lists <ul style="list-style-type: none"> – Resistance of materials used to chemicals • Data sheet <ul style="list-style-type: none"> – Technical specifications, operating conditions, dimensions • www.schmitt-pumpen.de/en/services/downloads 	
Spare parts list <ul style="list-style-type: none"> • Ordering spare parts 	Documentation included
Sectional drawing <ul style="list-style-type: none"> • Sectional drawing, part numbers, component designations 	
Documentation for the drive <ul style="list-style-type: none"> • Technical documentation for drives 	
Declaration of conformity <ul style="list-style-type: none"> • Conformity with standards • (→ 9.4 Declaration of conformity in accordance with EC machinery directive, Page 33). 	

Tab. 1 Other application documents, purpose and where found

1.3 Warnings and symbols

Warning sign	Level of risk	Consequences if disregarded
	immediate acute risk	Death, serious bodily harm
	potentially acute risk	Death, serious bodily harm
	potentially hazardous situation	Minor injury
	potentially hazardous situation	Material damage

Tab. 2 Warning signs and consequences if disregarded

Symbol	Meaning
	Safety warning sign ▶ Take note of all information highlighted by the safety warning sign and follow the instructions to avoid injury or death.
▶	Instruction
1., 2., ...	Multiple-step instructions
✓	Precondition
→	Cross reference
	Information, notes

Tab. 3 Symbols and their meaning

2 General safety instructions

 The manufacturer accepts no liability for damages caused by disregarding any of the documentation.

2.1 Intended use

- Only use the pump with suitable media. Pump parts in contact with media must be resistant to the media. (→ Order specification).
- Use the pump for flammable or explosive media only if it is intended for use in potentially explosive atmospheres (→ATEX additional instructions).
- Adhere to the operating limits and size-dependent minimum flow rates.
- Avoid dry running:
Initial damage, such as destruction of mechanical seals, seals and plastic parts, will occur within a few seconds.
 - Make sure the pump is only operated only when filled with the conveyed fluid and vented, and never operated when not filled with the pumped liquid.
 - Ensure that there are no excessively high amounts of gas in the pumping medium.
 - Ensure that the pump is operated only within the permissible operating range.
 - Ensure that the use of shut-off valves or filters does not cause the pressure on the inlet side of the pump to be too low.
- Avoid cavitation:
 - Open the suction-side fitting and do not use it to regulate the flow.
 - Do not open the pressure-side fitting beyond the agreed operating point.
- Avoid overheating:
 - Do not operate the pump while the pressure-side fitting is closed.
 - Note minimum flow (→ Data sheet).
- Avoid damage to the motor:
 - Do not open the pressure-side fitting beyond the agreed operating point.
 - Note the maximum permissible number of times the motor can be switched on per hour (→ manufacturer's specifications).
- Consult with the manufacturer regarding any other use of the device.

Prevention of obvious misuse (examples)

- Observe pump limits of use regarding temperature, pressure, flow and speed (→ data sheet).
- The power consumption of the pump increases as the specific gravity of the pumped fluid increases. Adhere to the permissible specific gravity in order to eliminate the possibility that the pump and motor become overloaded (→ data sheet).
A lower specific gravity is permissible. Adapt the auxiliary systems accordingly.

- When conveying fluids containing solids, observe the limit values for proportions of solid particles and particle size:
 - Particle size ≤ 3 mm
 - Proportion of solid particles ≤ 10 % Vol.
- The type of installation should be selected only in accordance with these operating instructions. For example, the following are not allowed:
 - Hanging pumps in the pipe
 - Overhead installation
 - Installation in the immediate vicinity of extreme heat or cold sources
 - Installation too close to a wall
 - Vertical installation

2.2 General safety instructions

 Observe the following regulations before carrying out any work.

2.2.1 Product safety

The pump has been built according to state-of-the-art technology and the recognized technical safety regulations. Nevertheless, operation of the pump can still put the life and health of the user or third parties at risk or damage the pump or other property.

- Operate the pump only if it is in perfect technical condition and use it only as intended, staying aware of safety and risks, and in adherence to the instructions in this manual.
- Keep this manual and all other applicable documents complete, legible and accessible to personnel at all times.
- Refrain from any procedures and actions that would pose a risk to personnel or third parties.
- In the event of any safety-relevant faults, shut down the pump immediately and have the fault corrected by appropriate personnel.
- In addition to the entire documentation for the product, comply with statutory or other safety and accident-prevention regulations and the applicable standards and guidelines in the country where the pump is operated.

2.2.2 Obligations of the operating company

Safety-conscious working

- Operate the pump only if it is in perfect technical condition and use it only as intended, staying aware of safety and risks, and in adherence to the instructions in this manual.
- Ensure that the following safety aspects are observed and monitored:
 - Intended use
 - Statutory or other safety and accident-prevention regulations
 - Safety regulations governing the handling of hazardous substances
 - Applicable standards and guidelines in the country where the pump is operated
 - Applicable guidelines of the operator
- Make personal protective equipment available.

Qualified personnel

- Make sure all personnel tasked with work on the pump have read and understood this manual and all other applicable documents, especially the safety, maintenance and repair information, before they start any work.
- Organize responsibilities, areas of competence and the supervision of personnel.
- Make sure that trainee personnel only work on the pump under supervision of specialist technicians.
- All activities may be carried out only by specialists who hold the required qualifications:

Actions	Required qualified personnel
Mechanical work (installation, maintenance, servicing)	Skilled mechanic
Electrical work (electrical installation)	Qualified electrician
All further work	Instruction by the user/owner

Safety equipment

- Provide the following safety equipment and verify its functionality:
 - For hot, cold and moving parts: pump safety guarding provided by the customer
 - For pumps without capability to run dry: Dry run protection

Warranty

- Obtain the manufacturer's approval prior to carrying out any modifications, repairs or alterations during the warranty period.
- Only use genuine parts or parts that have been approved by the manufacturer.

2.2.3 Obligations of personnel

- All directions given on the pump must be followed (and kept legible), e.g. the arrow indicating the sense of rotation and the markings for fluid connections.
- Pump, safety guarding and components:
 - Do not step on them or use as a climbing aid
 - Do not use them to support boards, ramps or beams
 - Do not use them as a fixing point for winches or supports
 - Do not use them for storing paper or similar materials
- Do not remove the safety guarding for hot, cold or moving parts during operation.
- If necessary, use protective equipment for the specific application:
 - Helmet
 - Safety gloves
 - Safety goggles
 - Gloves
 - Further protective equipment depending on the medium being pumped
- Only carry out work on the pump while it is not running.
- Before all installation and maintenance work, disconnect the motor from the mains and secure it against being switched back on again.
- Never reach into the suction or discharge flange.
- Following all work on the pump, refit safety devices in accordance with the instructions and bring into service.
- Do not make any modifications to the device.

2.3 Specific hazards
2.3.1 Potentially explosive atmospheres

Observe ATEX additional manual

- Additional instructions for use in explosive atmospheres
- (→ www.schmitt-pumpen.de/sites/default/files/2020-10/ATEX-Zusatzanleitung-en.pdf)

2.3.2 Electric shock

In the event of contact with live parts (e.g. wires in the terminal box of the electric motor), there is a risk of electric shock resulting in serious injury or death.

- All electrical work must be carried out by qualified electricians only.
- Before all work on the electrical system, disconnect the motor from the mains and secure against being switched back on again.

2.3.3 Hazardous pumped media sprayed out

Pumped media can be toxic and hot and can be sprayed out. In the event of contact, there is a risk of burns and skin rashes.

- When handling hazardous fluids (e.g. hot, flammable, explosive, toxic, hazardous to health or the environment), observe the safety regulations for the handling of hazardous substances.
- Allow the pump to cool completely before commencing any work and then depressurize it.
- Use protective equipment for any work on the pump.
- Empty the pump during maintenance and repair work.
- Safely collect the fluid and dispose of it in accordance with environmental regulations.

2.3.4 Moving parts

Moving parts (e.g. shaft, impeller, coupling) present a risk of fatal injury due to being dragged in, crushed or trapped.

- Do not touch the pump when it is running.
- Do not carry out any work on the pump when it is running.
- Maintain an adequate distance from moving parts.
- When performing installation and maintenance work, disconnect the motor from the mains and secure it against being switched back on again.
- (If present) ensure contact guard is fitted after work on the pump.

2.3.5 Hot surfaces

During operation, high temperatures are generated on the surfaces of the housing. Even after switching off, the surfaces of the housing can still be hot and can cool down only slowly. There is a risk of burns when touching hot surfaces.

- Do not touch the pump when it is running.
- Allow the pump to cool completely before commencing any work.
- Wear protective gloves.

3 Layout and Function

3.1 Marking

3.1.1 Name plate

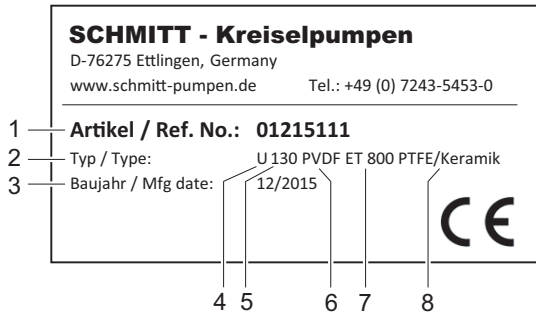

Fig. 1 Name plate (example)

- 1 Article numbers
- 2 Type
- 3 Year of manufacture (month/year)
- 4 Pump series
- 5 Size
- 6 Pump material
- 7 Immersion depth
- 8 Version

3.1.2 ATEX type plate



Fig. 2 ATEX type plate (example)

- 1 Explosion protection label

3.2 Description

Non-self-priming centrifugal pump in modular construction:

- Horizontal installation
- Direction of conveying
 - Suction flange, axial
 - Discharge flange, vertical
- Series U
 - Single acting mechanical seal
 - Housing and impeller made of plastic
 - For conveying acids, lyes and corrosive medias up to 95 °C
- Series UP
 - Single acting mechanical seal
 - Housing and impeller made of stainless steel
 - For conveying weak acids, lyes, corrosive media and emulsions at 150 °C
- Series UP-DO
 - Double acting mechanical seal
 - Housing and impeller made of stainless steel
 - For conveying weak acids, lyes, corrosive media and emulsions at 150 °C

3.3 Assembly

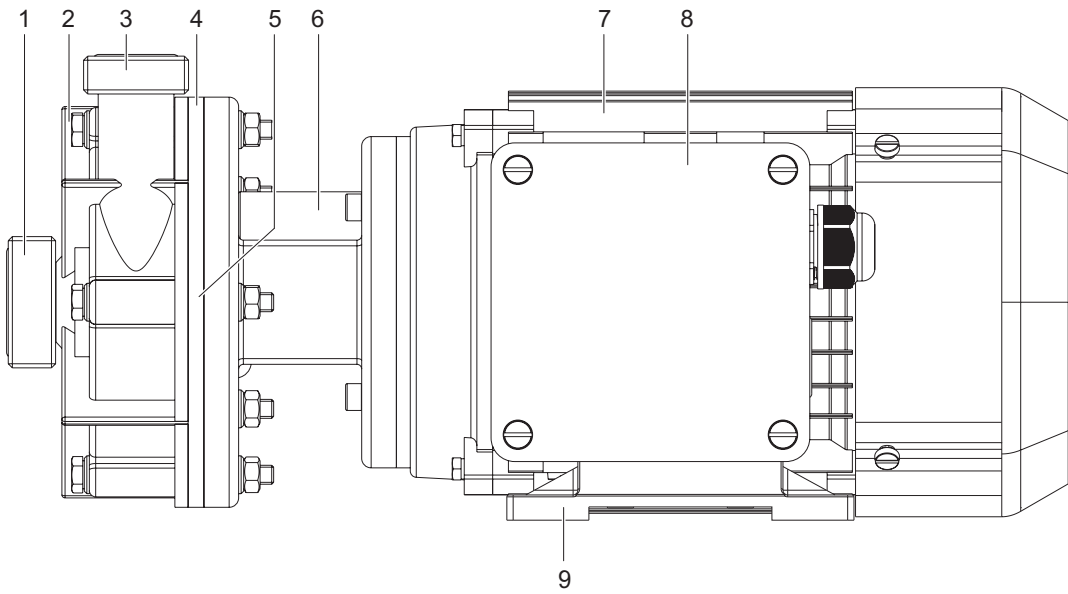

Fig. 3 Layout of series U

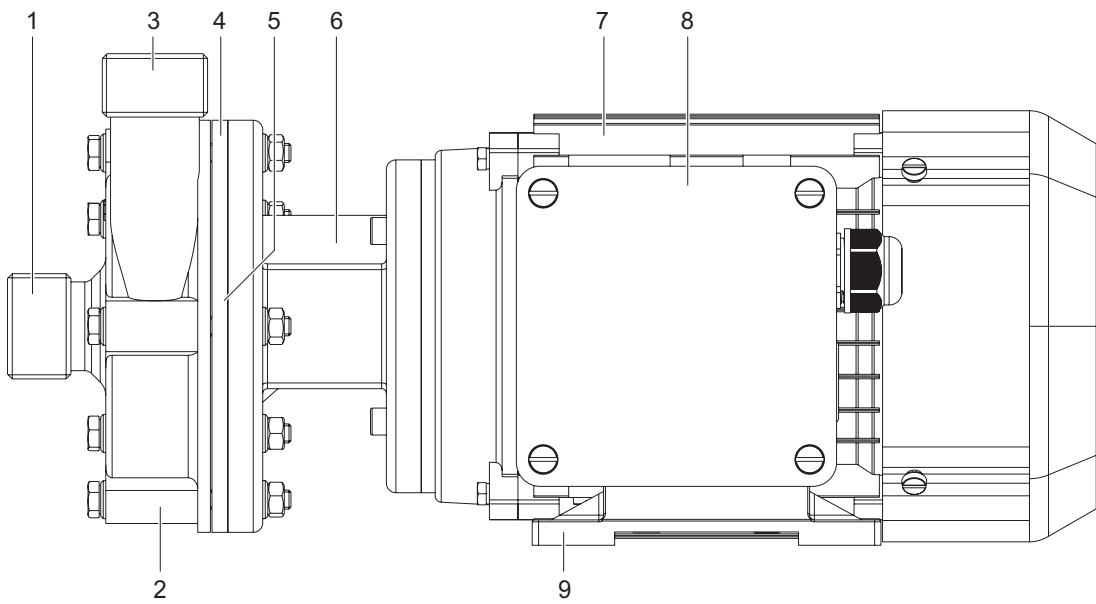

Fig. 4 Layout of series UP

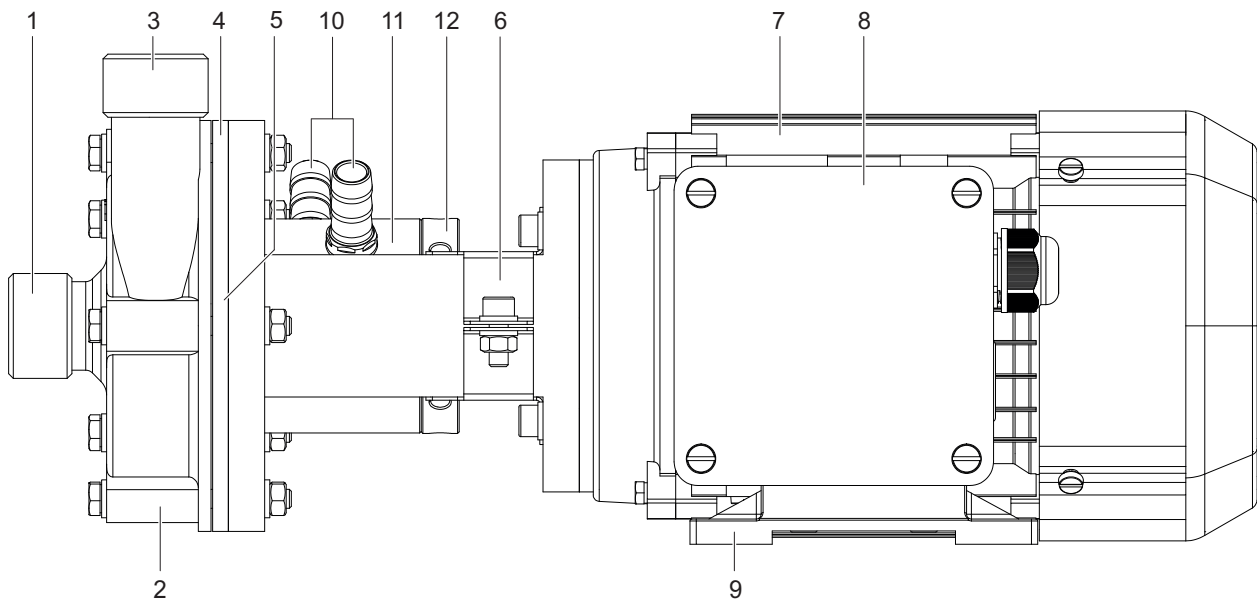



Fig. 5 Layout of series UP-DO

- 1 Suction branch
- 2 Housing
- 3 Discharge flange
- 4 Cover
- 5 Mechanical seal (concealed)
- 6 Flange with shaft protection
- 7 Motor
- 8 Terminal box
- 9 Motor foot
- 10 Hose nozzle
- 11 Sealing liquid container
- 12 Insert

3.4 Mechanical seal

 Mechanical seals have a functional leak.

Mechanical seal, following version:

- Single-acting (series U, UP)
- Double-acting (series UP-DO)
- Spring-loaded
- Media-lubricated
- Suitable for conveying pumped liquids with a low solid content (up to 3 mm grain size and 10% vol.)

4 Transport, Storage and Disposal

4.1 Transport

 The user/owner is responsible for the transport of the pump.

 Weight specification (→ Data sheet)

4.1.1 Unpacking and inspection on delivery

1. Unpack the pump/machine drive on delivery, and inspect it for transport damage.
2. Check completeness and accuracy of delivery.
3. Ensure that the information on the name plate agrees with the order/design data.
4. Report any transportation damage to the manufacturer immediately.
5. Dispose of packaging material according to local regulations.

4.1.2 Lifting

DANGER

Death or limbs crushed as a result transported items falling over!

- ▶ Use lifting gear appropriate for the total weight to be transported.
- ▶ Attach lifting gear in accordance with the following diagram.
- ▶ Do not stand under suspended loads.

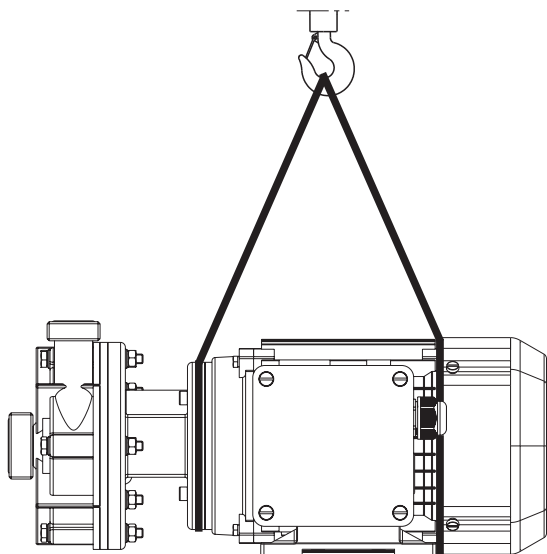

Fig. 6 Attach the lifting gear to the modular pump (illustration of general principle)

1. Attach lifting gear in accordance with the above diagram.
2. Lift the modular pump appropriately.

4.2 Storage

NOTE

Material damage due to inappropriate storage!

- ▶ Store the pump properly.

1. Seal all openings with blind plugs or plastic covers.
2. Make sure the storage room meets the following conditions:
 - Dry
 - Frost-free
 - Vibration-free
 - UV protected
3. Rotate the pump shaft twice a month.
4. Make sure the shaft and bearing change their rotational position in the process.

4.3 Disposal

 Plastic parts can be contaminated by poisonous or radioactive pumped liquids to such an extent that cleaning will be insufficient.

WARNING

Risk of poisoning and environmental damage by the pumped liquid!

- ▶ Use personal protective equipment when carrying out any work on the pump.
 - ▶ Prior to the disposal of the pump:
 - Collect and damage any escaping pumped liquid in accordance with local regulations.
 - Neutralize residues of pumped liquid in the pump.
 - ▶ Remove plastic parts and damage them in accordance with local regulations.
-
- ▶ Dispose of the pump in accordance with local regulations.

5 Installation and connection

 For pumps in potentially explosive atmospheres (→ ATEX additional manual).

NOTE

Material damage caused by dirt!

- ▶ Do not remove the transport seals until immediately before installing the pump.
- ▶ Do not remove any covers or transport and sealing covers until immediately before connecting the pipes to the pump.

5.1 Preparing for installation

5.1.1 Check operating conditions

- ▶ Ensure the required operating conditions are met:
 - Resistance of body and seal material to the medium (→ resistance lists).
 - Required ambient conditions (→ 9.2.1 Ambient conditions, Page 30).

5.1.2 Preparing the installation site

- ▶ Ensure the installation site meets the following conditions:
 - Pump is freely accessible from all sides
 - Sufficient space for the installation/removal of the pipes and for maintenance and repair work, especially for the removal and installation of the pump
 - Pump not exposed to external vibration (damage to bearings)
 - Pump not exposed to external corrosive influences
 - Frost protection

5.1.3 Prepare surface

- ✓ Aids, tools, materials:
 - Spirit level
- ▶ Ensure the surface meet the following conditions:
 - Level and horizontal
 - Clean (no oil, dust or other impurities)
 - Capable of bearing the weight of the machine drive and all operating forces
 - Ensures the stability of the machine drive

5.2 Setting up

1. Lift up the machine drive (→ 4.1 Transport, Page 13).
2. Put down the machine drive at the place of installation.
3. Screw the attachment bolts into the motor foot and tighten them.

5.3 Planning pipelines

 Water hammer may damage the pump or the system. Plan the pipes and fittings as far as possible to prevent water hammer occurring.

5.3.1 Designing pipelines

- ▶ Plan pipes safely:
 - No pulling or thrusting forces
 - No bending moments
 - Adjust for changes in length due to temperature changes (compensators, expansion shanks)
 - Avoid bends close to the suction flange

5.3.2 Arranging the supports and connections

NOTE

Material damage due to excessive forces and torques on the pump!

- ▶ Ensure pipe connection without stress.

1. Support pipes in front of the pump.
2. Ensure the pipe supports will always allow expansion and contraction of the pipes.

5.3.3 Specifying nominal widths

 Keep the flow resistance in the pipes as low as possible.

1. Make sure the nominal suction line width is not smaller than the nominal suction flange width.
2. Make sure the nominal pressure line width is not smaller than the nominal discharge flange width.

5.3.4 Specifying pipe lengths

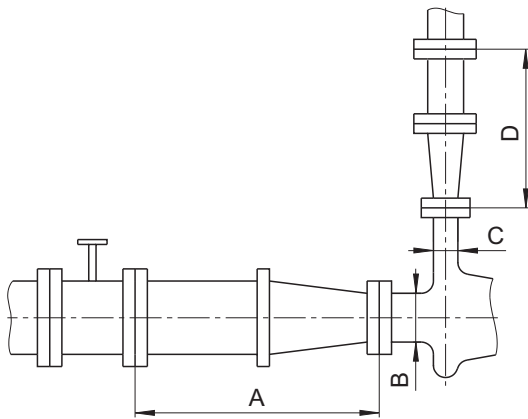

Fig. 7 Straight pipe lengths in front and after the pumps (recommended)

- A > 5x DN_s
- B DN_s
- C DN_d
- D > 5x DN_d

- ▶ Observe recommended minimum values when installing the pump.

- Suction side: Shorter lengths are possible, but may limit hydraulic performance data.
- Pressure side: Shorter lengths are possible, but may result in increased noise development.

5.3.5 Optimizing changes of cross section and direction

1. Avoid radii of curvature of less than 1.5 times the nominal pipe diameter.
2. Avoid abrupt changes of cross-section along the piping.

5.3.6 Providing safety and control devices (recommended)

Avoid contamination

1. Install a dirt strainer with mesh size < 3 mm in the suction pipe.
2. Install a differential pressure gauge with contact manometer to monitor contamination.

Avoid reverse running

1. Install a non-return fitting between the discharge flange and stop fitting, to ensure that the medium does not flow back after the pump is switched off.
2. In order to enable venting, include vent connection between discharge flanges and non-return fitting.

Make provisions for isolating and shutting off the pipes

- For maintenance and repair work.

- ▶ Provide shut-off valves in the suction pipe and pressure line.

Dry run protection by measuring the operating conditions

- ▶ Provide monitoring sensors for both pressure and flow rate, to protect the pump against dry running and consequential damage.

5.4 Connecting the pipes

NOTE

Material damage due to excessive forces and torques on the pump!

- ▶ Ensure pipe connection without stress.

5.4.1 Keeping the piping clean

NOTE

Material damage due to impurities in the pump!

- ▶ Make sure no impurities can enter the pump.

- ▶ Clean all piping parts and fittings prior to assembly.

5.4.2 Installing suction pipe

1. Remove the transport and sealing covers from the pump.
2. For intake operation always lay the suction line descending to the pump.
3. Fit suction pipe stress-free and sealed.

5.4.3 Installing the pressure pipe

1. Remove the transport and sealing covers from the pump.
2. Position the pressure flange facing upwards, so as to allow the pump head to be vented.
3. Fit the pressure line stress-free and sealed.

5.4.4 Mounting the sealing liquid supply for the UP-DO

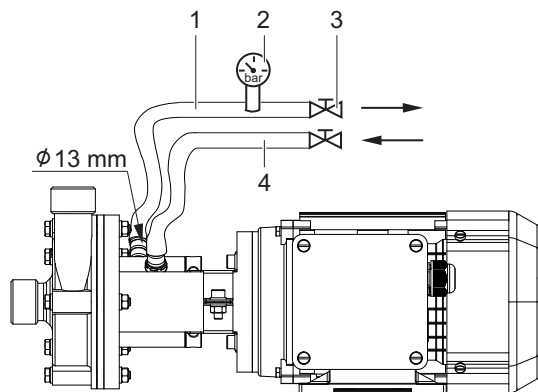

Fig. 8 Connection diagram for the sealing liquid supply

1. Connect the hose lines (1, 4) to the hose connectors for the flow direction indicated and so that they are free of stress.
2. Install the pressure indicator (2) and shut-off valves (3) in the hose lines.

5.4.5 Inspection for stress-free pipe connections

- ✓ Piping installed and cooled down

 1. Disconnect the pipe connections from the pump.
 2. Check whether the pipes can be moved freely in all directions within the expected range of expansion.
 3. Make sure that the connections are parallel.
 4. Reconnect the pipe connections to the pump.

5.5 Electrical connection



Risk of electrocution!

- ▶ All electrical work must be carried out only by qualified electricians.
- ▶ Before all work on the electrical system, disconnect the motor from the mains and secure against being switched back on again.

5.5.1 Connecting the motor

 Follow the instructions of the motor manufacturer.

1. Connect the motor according to the connection diagram.
2. Make sure no danger arises due to electric power.
3. Install an EMERGENCY STOP switch.

5.5.2 Check direction of rotation

 Only possible when starting up (→ 6.2 Commissioning, Page 17).

6 Operation

 For pumps in potentially explosive atmospheres (→ ATEX additional manual).

6.1 Preparing for commissioning

6.1.1 Check downtimes

- ▶ Before starting up the pump, check the downtime and perform the following actions:
 - Check the fill level.
 - If the hydraulic parts are dirty, clean them.
 - Check that the impeller runs freely.

6.1.2 Prepare the sealing liquid supply for the UP-DO

1. Ensure that the sealing liquid is appropriate to mix with the pumped medium.
2. Switch on the sealing liquid supply and ensure the required parameters are met (→ 9.2.8 Sealing liquid, Page 31).

6.1.3 Filling and bleeding

1. Open the suction-side fitting.
2. Open the pressure-side fitting.
3. Fill pump and suction pipe with fluid.
4. Verify that no pipe connections are leaking.

6.1.4 Check direction of rotation

NOTE

Material damage as a result of dry running!

- ▶ Make sure the pump is filled properly.
1. Switch on motor for max. 2 seconds and switch it off again immediately.
 2. Visually check the direction of rotation of the motor fan impeller and make sure that the direction of rotation of the motor matches the direction arrow on the pump casing.
 3. If the sense of rotation is different: Change over the two phases (→ 5.5 Electrical connection, Page 16).

6.2 Commissioning

6.2.1 Switching on

- ✓ Pump set up and connected properly
- ✓ Motor set up and connected properly
- ✓ All connections stress-free and sealed
- ✓ All safety equipment installed and tested for functionality
- ✓ Sealing liquid supply prepared for the UP-DO
- ✓ Pump prepared, filled and vented correctly

NOTE

Risk of cavitation if suction flow is restricted!

- ▶ Open the suction-side fitting and do not use it to regulate the flow.
- ▶ Do not open the pressure-side fitting beyond the operating point.

NOTE

Material damage due to overheating!

- ▶ Do not operate the pump for long periods with the pressure-side fitting closed.
- ▶ Observe the minimum flow rate (→ 9.2.6 Flow rate, Page 31).

NOTE

Material damage as a result of dry running!

- ▶ Make sure the pump is filled properly.
1. Open the suction-side fitting.
 2. Close the pressure-side fitting.
 3. Switch on the motor and check it for smooth running.
 4. Once the motor has reached its nominal speed, open the pressure-side fitting slowly until the operating point is reached.
 5. Make sure temperature change is smaller than 5 K/min for pumps with hot fluids.
 6. After the initial stress due to the pressure and operating temperature, check that the pump is not leaking.
 7. If leaks are present at the casing seals or connection flanges, proceed as follows:
 - Switch off motor.
 - Close the control valves.
 - Remedy the leaks.

6.2.2 Switching off

- ✓ Pressure-side fitting closed (recommended)
1. Switch off motor.
 2. Check all connecting bolts and tighten them to the specified torque (→ 9.2.5 Tightening torques of casing screws, Page 31).

6.3 Shutting down the pump

- ▶ Take the following measures whenever the pump is shut down:

Pump is	Measure
shut down	▶ Take measures appropriate for the fluid (→ Tab. 5 Measures depending on the behavior of the pumped liquid, Page 18).
...emptied	▶ Close suction and pressure-side fitting.
...dismounted	▶ Isolate the motor from its power supply and secure it against unauthorized switch-on.
...put into storage	▶ Note measures for storage (→ 4.2 Storage, Page 13).

Tab. 4 Measures to be taken if the pump is shut down

Behavior of the pumped liquid	Duration of shutdown (depending on process)	
	Short	Long
Crystallized or polymerized, solids sedimenting	▶ Flush the pump.	▶ Flush the pump.
Solidifying/ freezing, non-corrosive	▶ Heat up or empty the pump and containers.	▶ Empty the pump and containers.
Solidifying/ freezing, corrosive	▶ Heat up or empty the pump and containers.	▶ Empty the pump and containers.
Remains liquid, non-corrosive	–	–
Remains liquid, corrosive	–	▶ Empty the pump and containers.

Tab. 5 Measures depending on the behavior of the pumped liquid

6.4 Restoring the pump to service

- ▶ Complete all steps as for commissioning (→ [6.2 Commissioning, Page 17](#)).

6.5 Operating the stand-by pump

- ✓ Stand-by pump filled and bled

 Operate the stand-by pump at least once a week.

1. Fully open the suction-side fitting.
2. Open pressure-side fitting far enough so that the stand-by pump operating temperature is achieved and heating is even (→ [6.2.1 Switching on, Page 17](#)).

7 Maintenance

Opening the pump casing invalidates the warranty.

When used for the intended purpose the bearings and seals are virtually free of wear and will not require replacement during the warranty period.

Maintenance and repair work should be undertaken in consultation with Schmitt. The chapter describes maintenance not within the warranty period.

 For pumps in potentially explosive atmospheres (→ ATEX additional manual).

 Maintenance during the warranty period will be performed by Schmitt. Submit evidence of conveyed medium on request (DIN safety data sheet or confirmation of decontamination).

7.1 Inspections

 The inspection intervals depend on the operational strain on the pump.

1. Check at appropriate intervals:
 - Adherence to the minimum flow rate
 - Normal operating conditions unchanged
2. For trouble-free operation, always ensure the following:
 - No dry running
 - No leaks
 - No cavitation
 - Shut-off valve open on the suction side
 - Free and clean filters
 - Sufficient pump inlet pressure
 - No unusual running noises or vibrations

7.2 Servicing

 Mechanical seals are subject to natural wear and tear which is heavily dependent on the respective operating conditions. It is therefore not possible to make general statements about the operating life.

7.2.1 Maintenance in accordance with maintenance schedule

- ▶ Perform maintenance work in accordance with the maintenance schedule (→ [9.3 Maintenance schedule, Page 32](#)).

7.2.2 Maintaining the mechanical seal and shaft sleeve

 Follow the drawings for maintenance (→ [9.1.2 Drawings, Page 28](#)).

To maintain the mechanical seal and shaft sleeve, the pump is dismantled and mounted again following maintenance.

To maintain the shaft sleeve, the mechanical seal is dismantled.

Dismount the pump

- ✓ Tools, aids:
 - Circlip pliers

 1. Remove the hexagon screws, washers and nuts (04).
 2. Remove the housing (03).
 3. Remove the lock nut and washer (05).
 4. Use a wrench to restrain the shaft sleeve (09) at the bottom flange opening, and use circlip pliers to unscrew the impeller (06). Note the right-hand thread.

Dismounting and maintaining the mechanical seal

 Observe the manufacturer's specifications for the mechanical seal

- ✓ Pump dismantled

 1. For series U, UP proceed as follows:
 - Remove the sealing ring, thrust washer, rotating seal and compression spring from the shaft sleeve (09).
 - Remove the cover (10).
 - Press the bearing ring and counter ring out of the cover (10).
 2. For series UP-DO proceed as follows:
 - Unscrew the insert (19).
 - Pull off the sealing liquid container (20) incl. stationary seal.
 - Pull off the front mechanical seal (07).
 - Loosen the circlip (21).
 - Pull off rear mechanical seal (07) with spacer ring.
 - Pull off the insert (19).
 3. Check all parts of the mechanical seal (07) for damage. In case of damage, dispose of the entire mechanical seal and fit a new part.
 4. Proceed as follows as necessary:
 - Maintain the shaft sleeve (→ [Dismounting and maintaining the shaft sleeve, Page 20](#)).
 - OR –
 - Mount the mechanical seal and pump (→ [Mounting the mechanical seal and pump, Page 20](#)).

Dismounting and maintaining the shaft sleeve

-  Observe the manufacturer's specifications for the motor
- ✓ Mechanical seal dismantled
 - ✓ Tools, aids:
 - Vise
 - Shaft puller
 - Dial gage
 - Drill
1. Remove the grooved taper pin (13) from the motor shaft and motor sleeve (09) and dispose of it.
 2. Prepare the motor (15) for shaft sleeve disassembly as follows:
 - Remove the fan cover.
 - Remove the fan propeller.
 - Fix the motor with exposed shaft end on the fan side in a vise.
 3. Remove the shaft sleeve (09) from the motor shaft using a shaft puller.
 4. Clean the shaft sleeve (09) if necessary.
 5. Check the shaft sleeve (09). If the check results in the following, dispose of the shaft sleeve and fit a new part:
 - Shaft sleeve is damaged due to mechanical and chemical influences
 - Run-out precision at the shaft end > 0.02 mm
 6. Press the shaft sleeve (09) onto the end of the motor shaft, setting the correct installation dimension **B** (→ [9.2.3 Shaft sleeve installation dimensions, Page 30](#)).
 7. In case of a new shaft sleeve (09), drill a hole through the shaft sleeve and the motor shaft at the installation location **A**. Note the dimensions of the groove tapered pin (→ [9.2.3 Shaft sleeve installation dimensions, Page 30](#)).
 8. Insert the new grooved tapered pin (13) flush into the hole.
 9. Check the shaft sleeve (09) for run-out. Ensure a run-out precision at the shaft end of ≤ 0.02 mm.
 10. Mount the motor (15) as follows:
 - Remove the motor from the vise.
 - Mount the fan propeller.
 - Mount the fan cover.

Mounting the mechanical seal and pump

-  Observe the manufacturer's specifications for the mechanical seal
- ✓ Mechanical seal dismantled and checked
 - ✓ Shaft sleeve maintained if necessary

NOTE

Damage to mechanical seal!

- ▶ Do not get the mechanical seal dirty, especially the sealing surfaces of the slip rings.
 - ▶ Assemble the ceramic parts carefully; do not strike them or knock them.
-

1. For series U, UP mount the mechanical seal as follows:
 - Assemble the stationary seal and O-ring into a single unit.
 - Press the unit into the cover (10).
 - Mount the cover (10) on the flange (11).
 - Insert the sealing ring with the thrust washer in the rotating seal.
 - Slide the rotating seal with compression spring onto the shaft sleeve (09) until the rotating seal is in contact with the counter ring.
2. For series UP-DO, mount the mechanical seals as follows:
 - Push the insert (19) on to the shaft sleeve (09).
 - Push the rear mechanical seal (07) with spacer ring on to the shaft sleeve (09).
 - Install the circlip (21).
 - Push the front mechanical seal (07) on to the shaft sleeve (09).
 - Push the sealing liquid container (20) incl. stationary seal on to the shaft sleeve (09).
 - Screw the insert (19) on.
3. Screw the impeller (06) onto the shaft sleeve (09). Note the right-hand thread.
4. Screw on the washer and lock nut (05).
5. Check the housing seal (08) for damage. In case of damage, dispose of the housing seal and fit a new part.
6. Mount the housing (03).
7. Fit the hexagon screws, washers and nuts (04) and tighten them crosswise (→ [9.2.5 Tightening torques of casing screws, Page 31](#)).
8. Turn the shaft sleeve (09) and check whether it runs easily and smoothly.

7.2.3 Cleaning the pump

NOTE

High water pressure or spray water can cause material damage!

- ▶ Do not direct water jets or steam jets into the opening of the flange.
-
- ▶ Regularly clean the pump to remove heavy dirt.

7.3 Dismounting

WARNING

Risk of injury due to heavy components!

- ▶ Pay attention to the component weight. Lift and transport heavy components using suitable lifting gear.
- ▶ Set down components safely and secure them against overturning or rolling away.

WARNING

Risk of injury during disassembly!

- ▶ Secure the pressure-side shut-off valve against accidental opening.
- ▶ Wear protective gloves, components can become very sharp-edged due to wear or damage.
- ▶ Observe the manufacturer's specifications (e.g. for the motor).

NOTE

Material damage due to incorrect dismounting/installation of the pump!

- ▶ Only specialist mechanics should complete dismounting/installation work.

7.3.1 Preparations for dismounting

- ✓ Pump is depressurized
 - ✓ Pump completely empty, flushed and decontaminated
 - ✓ Electrical connections disconnected and motor secured against switch-on
 - ✓ Pump cooled down
 - ✓ For series UP-DO: sealing liquid supply switched off, depressurized and drained
 - ✓ Pressure gauge lines, pressure gauge and fixtures dismounted
1. Dismantle the pipes on the suction and pressure side.
 2. For the series UP-DO, remove the hose lines of the sealing liquid supply.
 3. Remove pump from the system.
 4. When dismounting, observe the following:
 - Mark the precise orientation and position of all components before dismounting them.
 - Dismount components concentrically without canting.

7.3.2 Dismount the pump

 Following the drawings for disassembly (→ 9.1.2 Drawings, Page 28).

Observe the manufacturer's specifications for the mechanical seal and motor.

- ✓ Tools, aids:
 - Circlip pliers
 - Vise
 - Shaft puller
1. Remove the hexagon nuts, washers and nuts (04).
 2. Remove the housing (03).
 3. With series U, remove the O-rings (01, 02).
 4. Remove the lock nut and washer (05).
 5. Secure the shaft sleeve (09) at the bottom flange opening with a wrench and unscrew the impeller (06) using circlip pliers. Note the right-hand thread.
 6. For series U, UP proceed as follows:
 - Remove the sealing ring, thrust washer, rotating seal and compression spring from the shaft sleeve (09).
 - Remove the cover (10).
 - Press the stationary seal and O-ring out of the cover (10).
 7. For series UP-DO proceed as follows:
 - Unscrew the insert (19).
 - Pull off the sealing liquid container (20) incl. stationary seal.
 - Pull off the front mechanical seal (07).
 - Loosen the circlip (21).
 - Pull off rear mechanical seal (07) with spacer ring.
 - Pull off the insert (19).
 - Unscrew the hose connectors (18).
 - Remove the O-rings (16, 17).
 8. Check all parts of the mechanical seal (07) for damage. In case of damage, dispose of the entire mechanical seal and fit a new part.
 9. Remove the housing seal (08).
 10. Remove the cylinder screws (14).
 11. Remove the flange (11).
 12. Remove the grip protection (12).
 13. Remove the grooved taper pin (13) from the motor shaft and motor sleeve (09) and dispose of it.
 14. Prepare the motor (15) for shaft sleeve disassembly as follows:
 - Remove the fan cover.
 - Remove the fan propeller.
 - Fix the motor with exposed shaft end on the fan side in a vise.
 15. Remove the shaft sleeve (09) from the motor shaft using a shaft puller.
 16. Check that the through holes and relief holes are not blocked - if they are, clean them.
 17. Mount the motor (15) as follows:
 - Remove the motor from the vise.
 - Mount the fan propeller.
 - Mount the fan cover.

7.4 Replacement parts and return

- Have the following information as shown on the name plate ready to hand when ordering spare parts (→ 3.1 Marking, Page 10).
 - Article numbers
 - Type
 - Year of manufacture
- Please complete and enclose the confirmation of decontamination for returns (→ www.schmitt-pumpen.de/sites/default/files/2020-10/Dekontaminationsnachweis_en.pdf).

- Use only spare parts from SCHMITT (E-Mail: sales@schmitt-pumpen.de).

7.5 Installing

-  Install components concentrically and without tilting in accordance with the markings applied.

WARNING

Risk of injury due to heavy components!

- ▶ Pay attention to the component weight. Lift and transport heavy components using suitable lifting gear.
- ▶ Set down components safely and secure them against overturning or rolling away.

WARNING

Risk of injury during assembly!

- ▶ Observe the manufacturer's specifications (e.g. for the motor).

NOTE

Material damage due to incorrect dismantling/installation of the pump!

- ▶ Only specialist mechanics should complete dismantling/installation work.

NOTE

Material damage due to unsuitable components!

- ▶ Always replace lost or damaged screws with screws of the same strength where required.
- ▶ Only replace seals with seals of the same material.

NOTE

Damage to mechanical seal!

- ▶ Do not get the mechanical seal dirty, especially the sealing surfaces of the slip rings.
- ▶ Assemble the ceramic parts carefully; do not strike them or knock them.

7.5.1 Preparations for installation

- ▶ When installing please observe:
 - Replace worn parts with genuine spare parts.
 - Replace seals, inserting them in such a way that they are unable to rotate.
 - Do not apply synthetic or mineral oil, grease or cleaning agents to elastomer components.

7.5.2 Installing the pump

-  Following the drawings for assembly (→ 9.1.2 Drawings, Page 28).

Observe the manufacturer's specifications for the mechanical seal and motor.

- ✓ Tools, aids:
 - Drill
 - Dial gage
- 1. Screw the flange (11) to the motor (15) crosswise using cylinder screws (14).
- 2. Press the shaft sleeve (09) onto the end of the motor shaft, setting the correct installation dimension **B** (→ 9.2.3 Shaft sleeve installation dimensions, Page 30).
- 3. In case of a new shaft sleeve (09), drill a hole through the shaft sleeve and the motor shaft at the installation location **A**. Note the dimensions of the groove tapered pin (→ 9.2.3 Shaft sleeve installation dimensions, Page 30).
- 4. Insert the new grooved tapered pin (13) flush into the hole.
- 5. Check the shaft sleeve (09) for run-out. Ensure a run-out precision at the shaft end of ≤ 0.02 mm.
- 6. If you detect a deviating run-out precision, realign the shaft sleeve (09).
- 7. Mount the grip protection (12) in the flange (11).
- 8. Insert the housing seal (08).
- 9. For series U, UP proceed as follows:
 - Assemble the stationary seal and O-ring into a single unit.
 - Press the unit into the cover (10).
 - Mount the cover (10) on the flange (11).
 - Insert the sealing ring with the thrust washer in the rotating seal.
 - Slide the rotating seal with compression spring onto the shaft sleeve (09) until the rotating seal is in contact with the counter ring.

10. For series UP-DO proceed as follows:
 - Install the O-rings (16, 17).
 - Screw in the hose connectors (18).
 - Push the insert (19) on to the shaft sleeve (09).
 - Push the rear mechanical seal (07) with spacer ring on to the shaft sleeve (09).
 - Install the circlip (21).
 - Push the front mechanical seal (07) on to the shaft sleeve (09).
 - Push the sealing liquid container (20) incl. stationary seal on to the shaft sleeve (09).
 - Screw the insert (19) on.
11. Screw the impeller (06) onto the shaft sleeve (09). Note the right-hand thread.
12. Screw on the washer and lock nut (05).
13. Mount the housing (03).
14. Fit the hexagon screws, washers and nuts (04) and tighten them crosswise ([→ 9.2.5 Tightening torques of casing screws, Page 31](#)).
15. Turn the shaft sleeve (09) and check whether it runs easily and smoothly.
16. With series U, mount the O-rings (01, 02).

7.5.3 Install the pump into the system

- ▶ Install the pump in the system. ([→ 5 Disposal, Page 14](#)).

8 Troubleshooting

 For pumps in potentially explosive atmospheres (→ ATEX additional manual).

If faults occur which are not specified in the following table or cannot be traced back to the specified causes, please consult the manufacturer.

Possible faults are identified by a fault number in the table below. This number identifies the respective cause and remedy in the troubleshooting list.

Fault	Number
Pump not pumping	1
Pumping rate insufficient	2
Pumping rate excessive	3
Pumping pressure insufficient	4
Pumping pressure excessive	5
Pump running roughly / loud noises / vibration	6
Pump leaks	7
Excessive motor power uptake	8
Housing temperature too high	9

Tab. 6 Fault/number assignment

Fault number									Cause	Remedy
1	2	3	4	5	6	7	8	9		
X	-	-	-	-	-	-	-	-	Intake / suction pipe and/or pressure line closed by fitting	▶ Open the fitting.
X	-	-	-	-	-	-	-	-	Transport and sealing cover still in place	▶ Remove the transport and sealing cover. ▶ Dismount the pump and inspect it for dry-running damage.
X	X	-	X	-	-	-	-	-	Motor speed too low	▶ Compare the required motor speed with the specifications on the pump type plate. Replace the motor if necessary. ▶ Increase the motor speed if speed control is available.
X	X	-	X	-	X	-	-	-	Intake / suction pipe, pump or suction strainer blocked or encrusted	▶ Clean intake/suction pipe, pump or suction strainer.
X	X	-	X	-	X	-	-	-	Air is sucked in	▶ Seal source of problem.
X	X	-	X	-	X	-	-	-	Proportion of gas too high: pump is cavitating	▶ Consult the manufacturer.
X	X	-	X	-	X	-	-	-	Pump running in the wrong direction	▶ Change over any two phases in the motor.
X	X	-	X	-	X	-	-	-	Impeller out of balance or blocked	▶ Dismount the pump and inspect it for dry-running damage. ▶ Clean the impeller.
X	X	-	-	X	X	-	-	-	Pressure pipe blocked	▶ Clean the pressure pipe.

Fault number									Cause	Remedy
1	2	3	4	5	6	7	8	9		
X	-	-	-	-	X	-	-	-	Intake/suction pipe and pump not correctly vented or not completely filled	▶ Completely fill and vent pump and/or pipe.
X	-	-	-	-	X	-	-	-	Intake / suction pipe contains trapped air	▶ Install fitting for venting. ▶ Adjust piping installation.
-	X	-	X	-	-	-	-	-	Intake / suction pipe not completely open	▶ Open the fitting.
-	X	-	X	-	X	-	-	-	Cross section of intake / suction pipe too narrow	▶ Increase cross section. ▶ Clean encrustation from suction pipe. ▶ Fully open fitting.
-	X	-	X	-	X	-	-	-	Hydraulic parts of the pump dirty, clotted or encrusted	▶ Dismount the pump. ▶ Clean the parts.
-	X	-	X	-	X	-	-	-	Suction head too large: $NPSH_{\text{pump}}$ is larger than $NPSH_{\text{system}}$	▶ Increase pump inlet pressure. ▶ Consult the manufacturer.
-	X	-	X	-	X	-	-	-	Back pressure of the system is too high, pump selected is too small.	▶ Consult the manufacturer.
-	X	-	X	-	X	-	-	-	Pump parts worn	▶ Replace the worn pump parts.
-	X	-	X	-	X	-	-	-	Pump jammed	▶ Consult the manufacturer. ▶ Check the solid content of the pumped liquid and reduce if necessary.
-	X	-	X	-	X	-	X	-	Motor running on 2 phases	▶ Check the fuse and replace it if necessary. ▶ Check the cable connections and insulation.
-	X	-	X	-	X	-	-	X	Temperature of fluid is too high: pump is cavitating	▶ Increase pump inlet pressure. ▶ Lower temperature. ▶ Contact the manufacturer.
-	X	-	X	-	-	-	X	X	Viscosity or specific gravity of the pumped liquid outside the range specified for the pump	▶ Consult the manufacturer.
-	X	-	X	-	-	-	-	X	Geodetic differential head and/or pipe flow resistances too high	▶ Remove sediments from the pump and/or pressure pipe. ▶ Install a larger impeller and consult the manufacturer. ▶ Reduce the system pressure.
-	X	-	-	X	X	-	-	-	Pressure-side fitting not opened wide enough	▶ Open the pressure-side fitting.
-	-	X	X	-	X	-	X	-	Pressure-side fitting opened too wide	▶ Throttle down at the pressure-side fitting. ▶ Machine the impeller down. Consult the manufacturer and adjust the impeller diameter.
-	-	X	-	X	-	-	-	-	Viscosity lower than expected	▶ Machine the impeller down. Consult the manufacturer and adjust the impeller diameter.
-	-	X	-	X	X	-	X	-	Motor speed too high	▶ Compare the required motor speed with the specifications on the pump type plate. Replace the motor if necessary. ▶ Reduce the motor speed if speed control is available.

Fault number									Cause	Remedy
1	2	3	4	5	6	7	8	9		
-	-	X	-	X	X	-	X	-	Impeller diameter too large	<ul style="list-style-type: none"> ▶ Throttle down the flow rate at the pressure-side fitting. Observe the minimum flow rate. ▶ Machine the impeller down. Consult the manufacturer and adjust the impeller diameter.
-	-	X	-	-	X	-	X	-	Geodetic differential head, pipe flow resistances and/or other resistances lower than specified	<ul style="list-style-type: none"> ▶ Throttle down the flow rate at the pressure-side fitting. Observe the minimum flow rate. ▶ Machine the impeller down. Consult the manufacturer and adjust the impeller diameter.
-	-	-	-	-	X	-	-	-	Pipes and fittings blocked	<ul style="list-style-type: none"> ▶ Disassemble and clean the pipes and fittings.
-	-	-	-	-	X	X	X	-	Pump distorted	<ul style="list-style-type: none"> ▶ Check the pipe connections and pump attachment. ▶ Check alignment of coupling. ▶ Check the attachment of the motor foot.
-	-	-	-	-	X	-	X	-	Mechanical seal defective	<ul style="list-style-type: none"> ▶ Change the mechanical seal ▶ Check the solid content of the pumped liquid and reduce if necessary.
-	-	-	-	-	-	X	-	-	Mechanical seal worn	<ul style="list-style-type: none"> ▶ Change the mechanical seal
-	-	-	-	-	-	X	-	-	Connecting bolts not correctly tightened	<ul style="list-style-type: none"> ▶ Check all connecting bolts and tighten them to the specified torque (→ 9.2.5 Tightening torques of casing screws, Page 31).
-	-	-	-	-	-	X	-	-	Faulty housing seal	<ul style="list-style-type: none"> ▶ Replace the housing seal.

Tab. 7 Troubleshooting list

9 Appendix

9.1 Replacement parts

9.1.1 Part numbers and designations

Part no.	Designation
01	O-ring suction side ¹
02	Pressure-side O-ring ¹
03	Housing
04	Hex-head bolt, washer, nut
05	Lock nut, washer
06	Impeller
07	Mechanical seal
08	Housing seal
09	Shaft sleeve
10	Cover
11	Flange
12	Grip protection
13	Grooved taper pin
14	Cylinder-head bolt
15	Motor
16	O-ring ²
17	O-ring ²
18	Hose nozzle ²
19	Insert ²
20	Sealing liquid container ²
21	Spring washer ²

Tab. 8 Designation of components according to part numbers

- 1) Part present only on the U series
- 2) Part present only on the series UP-DO

9.1.2 Drawings
Sectional drawing

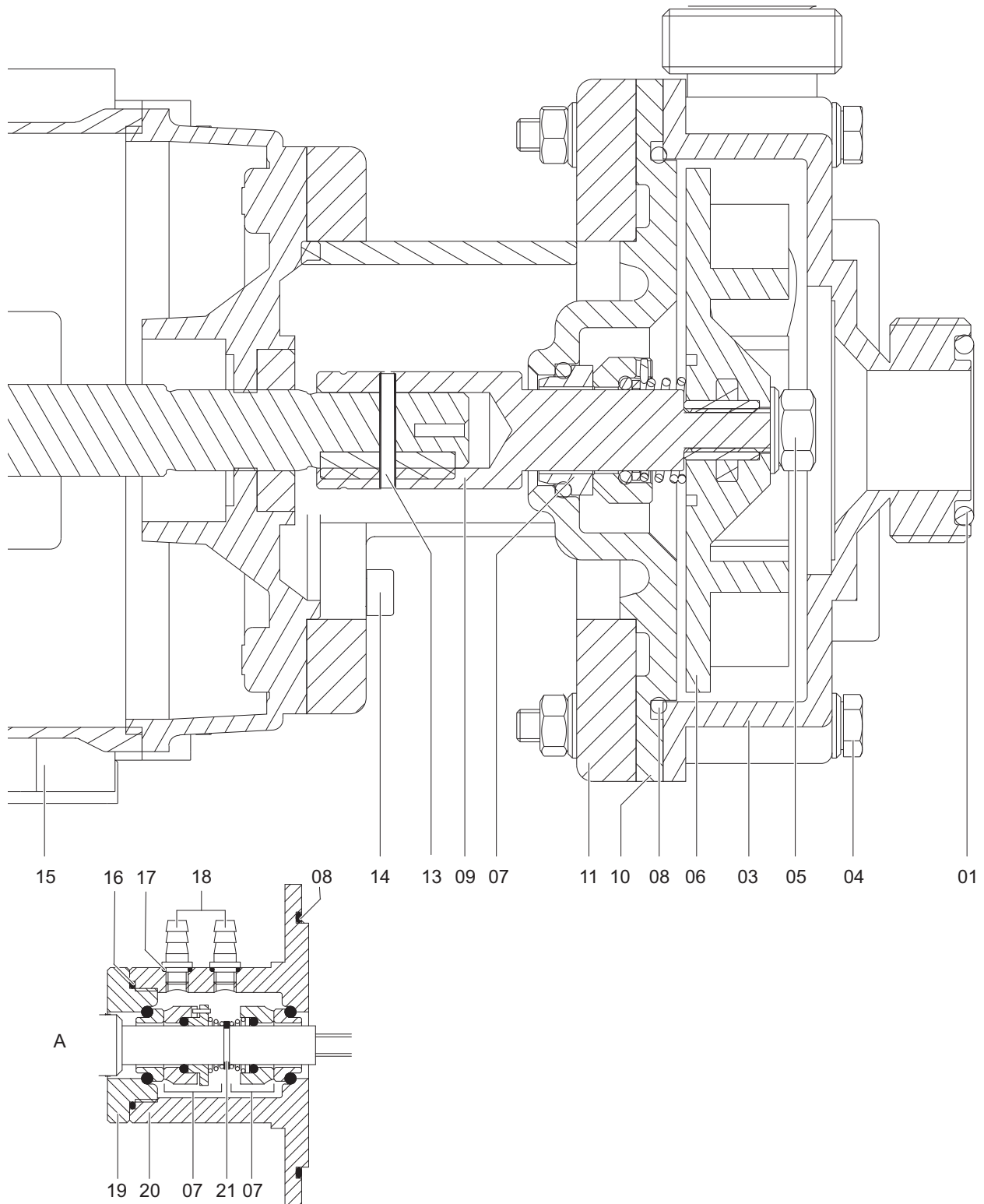

Fig. 9 Parts (sectional drawing)
A Parts for the series UP-DO

Exploded drawing

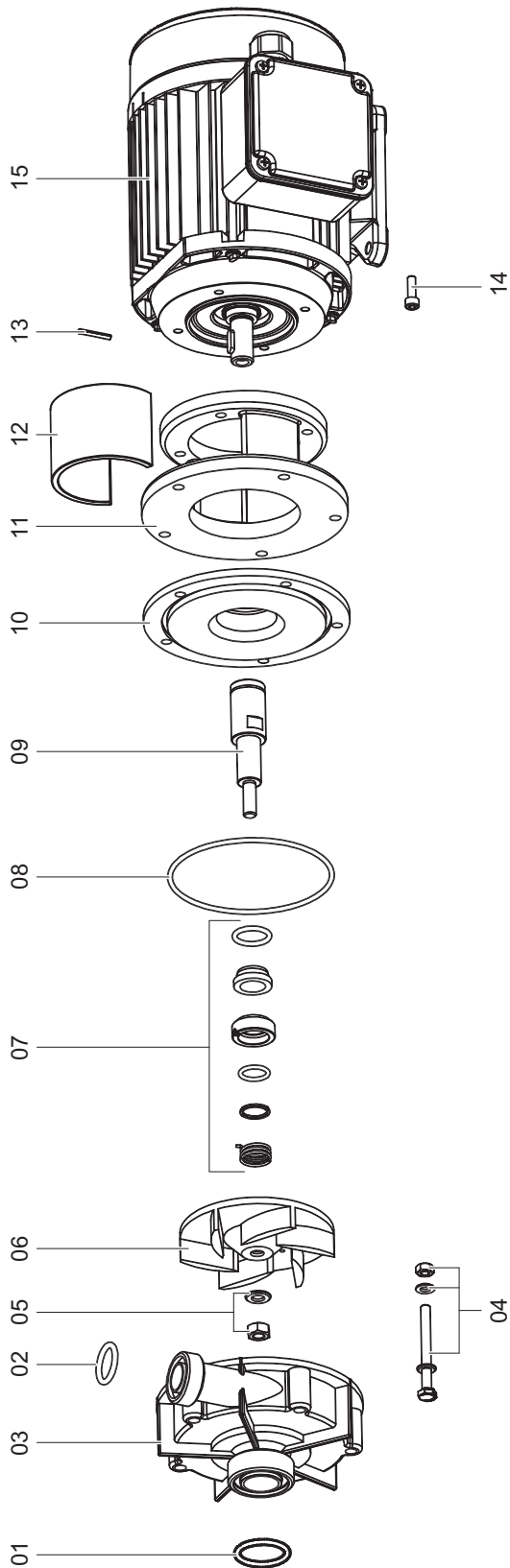



Fig. 10 Parts (exploded drawing), example series U

9.2 Technical specifications

 Further technical data (→ data sheet).

9.2.1 Ambient conditions

 Operation under any other ambient conditions should be agreed with the manufacturer.

Temperature [°C]	Relative humidity [%]		Installation height above sea level [m]
	Long-term	Short-term	
-20 to +40 ¹⁾	≤ 85	≤ 100	≤ 1000

Tab. 9 Ambient conditions

1) material-dependent

9.2.2 Total pressure

 Total pressure = system pressure + pressure build-up in the pump

Pressure for the sealing liquid container = max. total pressure applied * 1.2

Type	Max. permissible total pressure (p _t) [bar]
U	6
UP	10

Tab. 10 Total pressure

9.2.3 Shaft sleeve installation dimensions

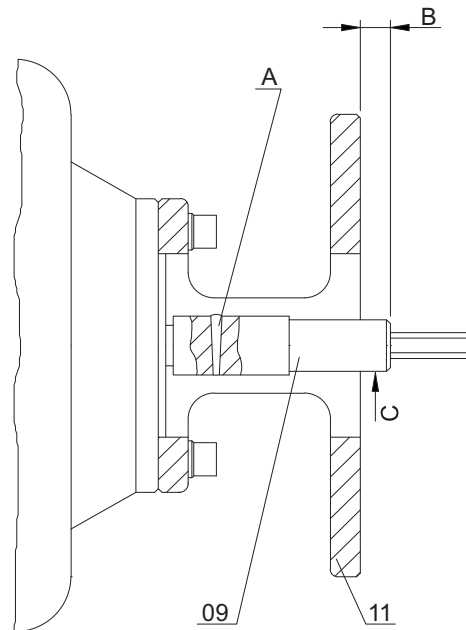

Fig. 11 Shaft sleeve installation dimensions

- A Dimensions and position of the grooved taper pin
- B Distance between flange (11) and shaft sleeve (09)
- C Shaft sleeve run-out (09)

Size	A Diameter x length [mm] ¹⁾	B [mm]		C [mm]
		Installation dimension	Axial play	
80	2 x 15	7.5	± 0.2	≤ 0.02
100	2 x 15	7.5		
115	3 x 20	7.5		
130	3 x 20	9.0		
150	4 x 25	11.0		
170	5 x 30	11.0		
190	5 x 30	11.0		
210	5 x 30	11.0		

Tab. 11 Installation dimensions

1) Grooved taper pin acc. to DIN 1471

9.2.4 Sound pressure level

Size	Sound pressure level [db (A)]
80	57
100	53
115	60
130	62
150	68
170	78
190	80

Tab. 12 Sound pressure level

Measuring conditions:

- Distance to the pump: 1 m
- Operation: cavitating, shut-off valve fully open
- Motor: IEC standard motor
- Tolerance ± 3 dB

9.2.5 Tightening torques of casing screws

Depending on the type of material of the pump, comply with the following tightening torques, and use a torque wrench:

Size	PVDF [Nm]	Stainless steel [Nm]
80	2	4
100	2	4
115	2	4
130	3	7
150	3	7
170	5	7
190	7	11
210	7	11

Tab. 13 Tightening torques of casing screws

9.2.6 Flow rate

The pump is operated within the following delivery flow rate limits:

Size	Motor power rating [kw]	Flow rate	
		Qmin [m ³ /h]	Qmax [m ³ /h]
80	0.18	0.15	2.0
100	0.18	0.30	3.9
115	0.25	0.66	5.5
130	0.55	0.72	8.1
130L	0.55	0.72	12.0
150	1.1	1.1	13.0
170	2.2	1.3	21.0
190	3.0	1.5	23.0
210	5.5	1.6	30.0

Tab. 14 Flow rate

9.2.7 Cleaning agents

- Weakly alkaline soap solution
- Steam jet (only for individual parts)

9.2.8 Sealing liquid

Parameter	Value
Characteristics	Non-flammable, non-corrosive, free of solids
Temperature	0 °C < T Sealing liquid < 60 °C
Viscosity	< 10 mPa*s
Pressure for the sealing liquid container	Max. total pressure applied * 1.2

Tab. 15 Characteristics of the sealing liquid

9.3 Maintenance schedule

i The manufacture recommends shorter maintenance intervals if the medium being conveyed contains solid matter. The operating company should choose the maintenance intervals appropriate to the medium being conveyed.

Interval	Designation	Action
Daily	Conveyed fluid	<ul style="list-style-type: none"> ▶ Check temperature. ▶ Check discharge pressure.
Weekly	Operating temperatures	▶ Check motor temperature.
	Pump	▶ Check the pump for leaks and vibration.
Quarterly	Undoable screwed connections	▶ Check all connecting bolts and tighten them to the specified torque (→ 9.2.5 Tightening torques of casing screws, Page 31).
	Mechanical seal	▶ Check the mechanical seal for wear and damage and change it if necessary.
	Shaft sleeve	<ul style="list-style-type: none"> ▶ Check the shaft sleeve for dirt, damage and correct run-out: <ul style="list-style-type: none"> – If the shaft sleeve is dirty, clean it. – If the shaft sleeve is damaged, replace it. – Ensure a run-out at the shaft sleeve end of ≤ 0.02 mm.
	Impeller	<ul style="list-style-type: none"> ▶ Check the impeller for dirt and damage: <ul style="list-style-type: none"> – If the impeller is dirty, clean it. – If the impeller is damaged, replace it.
	Housing seal	▶ Visually check the housing seal for damage and change it if necessary.
As required	Motor	▶ Check the motor against the supplier's documentation and perform maintenance if necessary (→ 1.2 Other applicable documents, Page 5).

Tab. 16 Maintenance schedule

9.4 Declaration of conformity in accordance with EC machinery directive

EU Declaration of Conformity



Manufacturer **SCHMITT-Kreiselpumpen GmbH & Co. KG**
Einsteinstrasse 33
D-76275 Ettlingen

Type of pump **Centrifugal pump**

Pump type **U 80, U 100, U 115, U 130, U 150, U 170, U 190, U 210**

UP 80, UP 100, UP 115, UP 130, UP 130L, UP 150, UP 170, UP 191, UP 211

UP-DO 100, UP-DO 115, UP-DO 130, UP-DO 150, UP-DO 170, UP-DO 190, UP-DO 210

We declare that the design of the listed pumps satisfies the provisions of the EU Directives.
The relevant points satisfy the requirements of the

EC Machinery Directive	2006 / 42 / EC
Low Voltage Directive	2014 / 35 / EU
Electromagnetic Compatibility	2014 / 30 / EU
Harmonized standards applied	EN ISO 12100:2010 EN 809:1998+A1:2009+AC:2010



Detlef Brandt
Einsteinstrasse 33, 76275 Ettlingen
CEO/Document Controller
SCHMITT-Kreiselpumpen GmbH & Co. KG