

NEOChem Base series Magnetically coupled centrifugal pump

Original operating manual

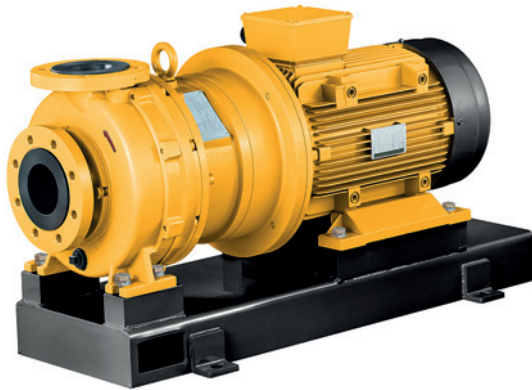

Version 01/2026
Print-No.

SCHMITT-Kreiselpumpen GmbH & Co. KG
Einsteinstraße 33
76275 Ettlingen
Germany
Phone: + 49 (0) 7243 / 54 53 - 0
E-Mail: sales@schmitt-pumpen.de
Internet: www.schmitt-pumpen.de

Subject to technical modifications.

Read carefully before use.
Save for future use.



Table of contents

1 About this document	5	5.4 Connecting the pipes	17
1.1 Target groups	5	5.4.1 Keeping the piping clean	17
1.2 Other applicable documents	5	5.4.2 Installing suction pipe	17
1.3 Warnings and symbols	6	5.4.3 Installing the pressure pipe	17
2 General safety instructions	7	5.4.4 Inspection for stress-free pipe connections	17
2.1 Intended use	7	5.5 Electrical connection	17
2.2 General safety instructions	7	5.5.1 Connecting the motor	17
2.2.1 Product safety	7	6 Operation	18
2.2.2 Obligations of the operating company	8	6.1 Preparing for commissioning	18
2.2.3 Obligations of personnel	8	6.1.1 Check downtimes	18
2.3 Specific hazards	8	6.1.2 Filling and bleeding	18
2.3.1 Potentially explosive atmospheres	8	6.1.3 Check direction of rotation	18
2.3.2 Electric shock	8	6.2 Commissioning	18
2.3.3 Hazardous pumped media sprayed out	9	6.2.1 Switching on	18
2.3.4 Moving parts	9	6.2.2 Switching off	18
2.3.5 Hot surfaces	9	6.3 Shutting down the pump	19
2.3.6 Magnetic field	9	6.4 Restoring the pump to service	19
3 Layout and Function	10	6.5 Operating the stand-by pump	19
3.1 Marking	10	7 Maintenance	20
3.1.1 Name plate	10	7.1 Inspections	20
3.1.2 ATEX type plate	10	7.2 Servicing	20
3.2 Description	11	7.2.1 Maintenance in accordance with maintenance schedule	20
3.3 Assembly	11	7.2.2 Cleaning the pump	20
3.4 Magnetic coupling	11	7.3 Dismounting	20
4 Transport, Storage and Disposal	12	7.3.1 Preparations for dismounting	20
4.1 Transport	12	7.3.2 Disassembling and checking the pump	21
4.1.1 Unpacking and inspection on delivery	12	7.4 Replacement parts and return	23
4.1.2 Lifting	12	7.5 Installing	24
4.2 Storage	12	7.5.1 Preparations for installation	24
4.3 Disposal	13	7.5.2 Assembly of the pump	24
5 Installation and connection	14	7.5.3 Install the pump into the system	25
5.1 Preparing for installation	14	8 Troubleshooting	26
5.1.1 Check operating conditions	14	9 Appendix	29
5.1.2 Preparing the installation site	14	9.1 Parts	29
5.1.3 Surface preparation	14	9.1.1 Part numbers and designations	29
5.2 Setting up	14	9.1.2 Drawings	30
5.3 Planning pipelines	14	9.2 Installation example	34
5.3.1 Designing pipelines	14	9.3 Technical specifications	35
5.3.2 Arranging the supports and connections	14	9.3.1 Ambient conditions	35
5.3.3 Specifying nominal widths	14	9.3.2 Total pressure	35
5.3.4 Determine the pipe lengths and installation parameters	15	9.3.3 Sound pressure level	35
5.3.5 Overview of installation conditions for pipelines	16	9.3.4 Tightening torques	35
5.3.6 Optimizing changes of cross section and direction	17	9.3.5 Wear limits	36
5.3.7 Providing safety and control devices (recommended)	17	9.3.6 Permissible forces and torques on the suction flange and pressure flange	37
		9.3.7 Screw specification for the flanges	37
		9.3.8 Minimum volume flow	37
		9.3.9 Cleaning agents	37

9.4	Maintenance schedule	38
9.5	Declaration of conformity	39

List of figures

Fig. 1	Name plate (example)	10
Fig. 2	ATEX type plate (example)	10
Fig. 3	Assembly	11
Fig. 4	Attach the lifting gear to the modular pump (illustration of general principle)	12
Fig. 5	Pipe lengths and installation parameters	15
Fig. 6	Permissible (ü) and impermissible(X) installation conditions	16
Fig. 7	Components of the plain bearings	21
Fig. 8	Parts (sectional drawing), sizes 50-32-200 and 65-50-160	30
Fig. 9	Parts (sectional drawing), sizes 65-40-200 and 80-65-160	31
Fig. 10	Parts (exploded view), size 50-32-200	32
Fig. 11	Parts (exploded view), size 65-50-160	32
Fig. 12	Parts (exploded view), size 65-40-200	33
Fig. 13	Parts (exploded view), size 80-65-160	33
Fig. 14	Installation example	34
Fig. 15	Total pressure	35
Fig. 16	Forces and torques on the suction flange and pressure flange	37

List of tables

Tab. 1	Other application documents, purpose and where found	5
Tab. 2	Warning signs and consequences if disregarded	6
Tab. 3	Symbols and their meaning	6
Tab. 4	Measures to be taken if the pump is shut down	19
Tab. 5	Measures depending on the behavior of the pumped liquid	19
Tab. 6	Fault/number assignment	26
Tab. 7	Troubleshooting list	28
Tab. 8	Naming of components by part number, sizes 65-40-200 and 80-65-160	29
Tab. 9	Naming of components by part number, sizes 50-32-200 and 65-50-160	29
Tab. 10	Ambient conditions	35
Tab. 11	Sound pressure level	35
Tab. 12	Tightening torques for the housing	35
Tab. 13	Tightening torques for the suction flange and pressure flange	35
Tab. 14	Wear limits	36
Tab. 15	Forces and torques on the suction flange	37
Tab. 16	Forces and torques on the pressure flange	37
Tab. 17	Minimum volume flow	37
Tab. 18	Maintenance schedule	38

1 About this document

This manual:

- is an integral part of the pump
- applies to all series referred to
- describes safe and proper operation during all operating phases

1.1 Target groups

Operating company

- Responsibilities:
 - Always keep this manual accessible where the device is used on the system.
 - Ensure that employees read and observe this document, particularly the safety instructions and warnings, and the documents which also apply.
 - Observe any additional country-specific rules and regulations that relate to the system.

Qualified personnel, fitter





- Mechanics qualification:
 - Qualified employees with additional training for fitting the respective pipework
- Electrical qualification:
 - Qualified electrician
- Transport qualification:
 - Qualified transport specialist
- Responsibility:
 - Read, observe and follow this manual and the other applicable documents, especially all safety instructions and warnings.

1.2 Other applicable documents



Document/purpose	Where found
The following documents are available online: <ul style="list-style-type: none"> • ATEX additional instructions • Resistance lists <ul style="list-style-type: none"> – Resistance of materials used to chemicals • Data sheet <ul style="list-style-type: none"> – Technical specifications, operating conditions, dimensions • www.schmitt-pumpen.de/en/services/downloads 	
Spare parts list <ul style="list-style-type: none"> • Ordering spare parts 	Documentation included
Sectional drawing <ul style="list-style-type: none"> • Sectional drawing, part numbers, component designations 	
Documentation for the drive <ul style="list-style-type: none"> • Technical documentation for drives 	
Declaration of conformity <ul style="list-style-type: none"> • Conformity with standards • (→ 9.5 Declaration of conformity, Page 39). 	

Tab. 1 Other application documents, purpose and where found

1.3 Warnings and symbols

Warning sign	Level of risk	Consequences if disregarded
	immediate acute risk	Death, serious bodily harm
	potentially acute risk	Death, serious bodily harm
	potentially hazardous situation	Minor injury
	potentially hazardous situation	Material damage

Tab. 2 Warning signs and consequences if disregarded

Symbol	Meaning
	Safety warning sign ▶ Take note of all information highlighted by the safety warning sign and follow the instructions to avoid injury or death.
▶	Instruction
1., 2., ...	Multiple-step instructions
✓	Precondition
→	Cross reference
	Information, notes

Tab. 3 Symbols and their meaning

2 General safety instructions

 The manufacturer accepts no liability for damages caused by disregarding any of the documentation.

2.1 Intended use

- Only use the pump with suitable media. Pump parts in contact with media must be resistant to the media. (→ Order specification).
- Use the pump for flammable or explosive media only if it is intended for use in potentially explosive atmospheres (→ATEX additional instructions).
- Adhere to the operating limits and size-dependent minimum flow rates.
- Avoid dry running:
Initial damage, such as destruction of plain bearings, seals and plastic parts, will occur within a few seconds.
 - Make sure the pump is only operated only when filled with the conveyed fluid and vented, and never operated when not filled with the pumped liquid.
 - Ensure that there are no excessively high amounts of gas in the pumping medium.
 - Ensure that the pump is operated only within the permissible operating range.
 - Ensure that the use of shut-off valves or filters does not cause the pressure on the inlet side of the pump to be too low.
- Avoid cavitation:
 - Open the suction-side fitting and do not use it to regulate the flow.
 - Do not open the pressure-side fitting beyond the agreed operating point.
- Avoid overheating:
 - Do not operate the pump while the pressure-side fitting is closed.
 - Observe the minimum flow rate (→ 9.3 Technical specifications, Page 35).
- Avoid damage to the motor:
 - Do not open the pressure-side fitting beyond the agreed operating point.
 - Note the maximum permissible number of times the motor can be switched on per hour (→ manufacturer's specifications).
- Consult with the manufacturer regarding any other use of the device.

Prevention of obvious misuse (examples)

- Observe pump limits of use regarding temperature, pressure, flow and speed (→ 9.3 Technical specifications, Page 35).
- The power consumption of the pump increases as the specific gravity of the pumped fluid increases. Adhere to the permissible specific gravity in order to eliminate the possibility that the pump and motor become overloaded (→ 9.3 Technical specifications, Page 35).
A lower specific gravity is permissible. Adapt the auxiliary systems accordingly.
- When conveying fluids containing solids, observe the limit values for proportions of solid particles and particle size:
 - Particle size $\varnothing \leq 0.05$ mm
 - Proportion of solid particles ≤ 5 % Vol.
 - Hardness within 80 Hs
- If plain bearings of carbon-bonded silicon carbide are fitted, do not pump any liquids containing solids.
- The type of installation should be selected only in accordance with these operating instructions. For example, the following are not allowed:
 - Hanging pumps in the pipe
 - Overhead installation
 - Installation in the immediate vicinity of extreme heat or cold sources
 - Installation too close to a wall
 - Vertical installation

2.2 General safety instructions

 Observe the following regulations before carrying out any work.

2.2.1 Product safety

The pump has been built according to state-of-the-art technology and the recognized technical safety regulations. Nevertheless, operation of the pump can still put the life and health of the user or third parties at risk or damage the pump or other property.

- Operate the pump only if it is in perfect technical condition and use it only as intended, staying aware of safety and risks, and in adherence to the instructions in this manual.
- Keep this manual and all other applicable documents complete, legible and accessible to personnel at all times.
- Refrain from any procedures and actions that would pose a risk to personnel or third parties.
- In the event of any safety-relevant faults, shut down the pump immediately and have the fault corrected by appropriate personnel.
- In addition to the entire documentation for the product, comply with statutory or other safety and accident-prevention regulations and the applicable standards and guidelines in the country where the pump is operated.

2.2.2 Obligations of the operating company

Safety-conscious working

- Operate the pump only if it is in perfect technical condition and use it only as intended, staying aware of safety and risks, and in adherence to the instructions in this manual.
- Ensure that the following safety aspects are observed and monitored:
 - Intended use
 - Statutory or other safety and accident-prevention regulations
 - Safety regulations governing the handling of hazardous substances
 - Applicable standards and guidelines in the country where the pump is operated
 - Applicable guidelines of the operator
- Make personal protective equipment available.

Qualified personnel

- Make sure all personnel tasked with work on the pump have read and understood this manual and all other applicable documents, especially the safety, maintenance and repair information, before they start any work.
- Organize responsibilities, areas of competence and the supervision of personnel.
- Make sure that trainee personnel only work on the pump under supervision of specialist technicians.
- All activities may be carried out only by specialists who hold the required qualifications:

Actions	Required qualified personnel
Mechanical work (installation, maintenance, servicing)	Skilled mechanic
Electrical work (electrical installation)	Qualified electrician
All further work	Instruction by the user/owner

Safety equipment

- Provide the following safety equipment and verify its functionality:
 - For hot, cold and moving parts: pump safety guarding provided by the customer
 - For pumps without capability to run dry: Dry run protection

Warranty

- Obtain the manufacturer's approval prior to carrying out any modifications, repairs or alterations during the warranty period.
- Only use genuine parts or parts that have been approved by the manufacturer.

2.2.3 Obligations of personnel

- All directions given on the pump must be followed (and kept legible), e.g. the arrow indicating the sense of rotation and the markings for fluid connections.
- Pump and components:
 - Do not step on them or use as a climbing aid
 - Do not use them to support boards, ramps or beams
 - Do not use them as a fixing point for winches or supports
 - Do not use them for storing paper or similar materials
- Do not remove the safety guarding for hot, cold or moving parts during operation.
- If necessary, use protective equipment for the specific application:
 - Helmet
 - Safety gloves
 - Safety goggles
 - Gloves
 - Further protective equipment depending on the medium being pumped
- Only carry out work on the pump while it is not running.
- Before all installation and maintenance work, disconnect the motor from the mains and secure it against being switched back on again.
- Never reach into the suction or pressure-side flange.
- Following all work on the pump, refit safety devices in accordance with the instructions and bring into service.
- Do not make any modifications to the device.

2.3 Specific hazards

2.3.1 Potentially explosive atmospheres

Observe ATEX additional manual

- Additional instructions for use in explosive atmospheres
- (→ www.schmitt-pumpen.de/sites/default/files/2020-10/ATEX-Zusatzanleitung-en.pdf)



2.3.2 Electric shock

In the event of contact with live parts (e.g. wires in the terminal box of the electric motor), there is a risk of electric shock resulting in serious injury or death.

- All electrical work must be carried out by qualified electricians only.
- Before all work on the electrical system, disconnect the motor from the mains and secure against being switched back on again.

2.3.3 Hazardous pumped media sprayed out

Pumped media can be toxic and hot and can be sprayed out. In the event of contact, there is a risk of burns and skin rashes.

- When handling hazardous fluids (e.g. hot, flammable, explosive, toxic, hazardous to health or the environment), observe the safety regulations for the handling of hazardous substances.
- Allow the pump to cool completely before commencing any work and then depressurize it.
- Use protective equipment for any work on the pump.
- Empty the pump during maintenance and repair work.
- Safely collect the fluid and dispose of it in accordance with environmental regulations.

2.3.4 Moving parts

Moving parts (e.g. shaft, impeller, coupling) present a risk of fatal injury due to being dragged in, crushed or trapped.

- Do not touch the pump when it is running.
- Do not carry out any work on the pump when it is running.
- Maintain an adequate distance from moving parts.
- When performing installation and maintenance work, disconnect the motor from the mains and secure it against being switched back on again.
- (If present) ensure contact guard is fitted after work on the pump.

2.3.5 Hot surfaces

During operation, high temperatures are generated on the surfaces of the housing. Even after switching off, the surfaces of the housing can still be hot and can cool down only slowly. There is a risk of burns when touching hot surfaces.

- Do not touch the pump when it is running.
- Allow the pump to cool completely before commencing any work.
- Wear protective gloves.

2.3.6 Magnetic field

The magnetic field of the magnetic coupling can destroy products and devices that are sensitive to magnets. These include electronic implants (such as pacemakers), digital watches, calculators, hard drives, credit cards and ID cards. For persons with electronic implants there is a danger to life.

- Do not allow persons with electronic implants to work on the pump or on magnetic parts.
- Secure the work place and if necessary cordon off:
 - Ensure that persons with electronic implants maintain a safe distance > 1 m
 - Make sure that no magnetizable metal parts are attracted by the pump's magnetic coupling.
 - Make sure that parts of the magnetic coupling are not attracted by the magnetizable metal parts
- Keep magnetizable objects a safe distance > of 150 mm away from the magnetic coupling.

3 Layout and Function

3.1 Marking

3.1.1 Name plate

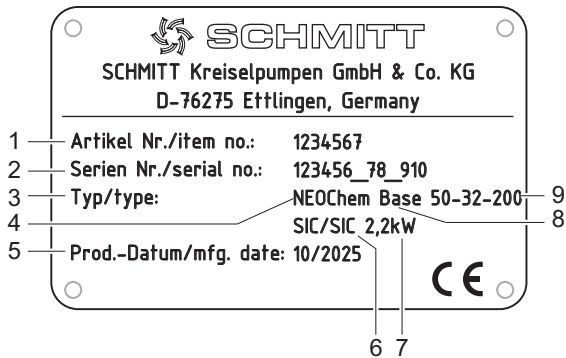

Fig. 1 Name plate (example)

- 1 Article numbers
- 2 Serial number
- 3 Type
- 4 Pump series
- 5 Year of manufacture (month/year)
- 6 Plain bearing material
- 7 Rated power of motor
- 8 „Base“ version
- 9 Size

3.1.2 ATEX type plate



Fig. 2 ATEX type plate (example)

- 1 Explosion protection label

3.2 Description

Non self-priming and magnetically coupled centrifugal pump in modular design:

- Media-lubricated plain bearings
- Horizontal installation
- Direction of conveying
 - Axial suction flange
 - Vertical pressure flange

3.3 Assembly

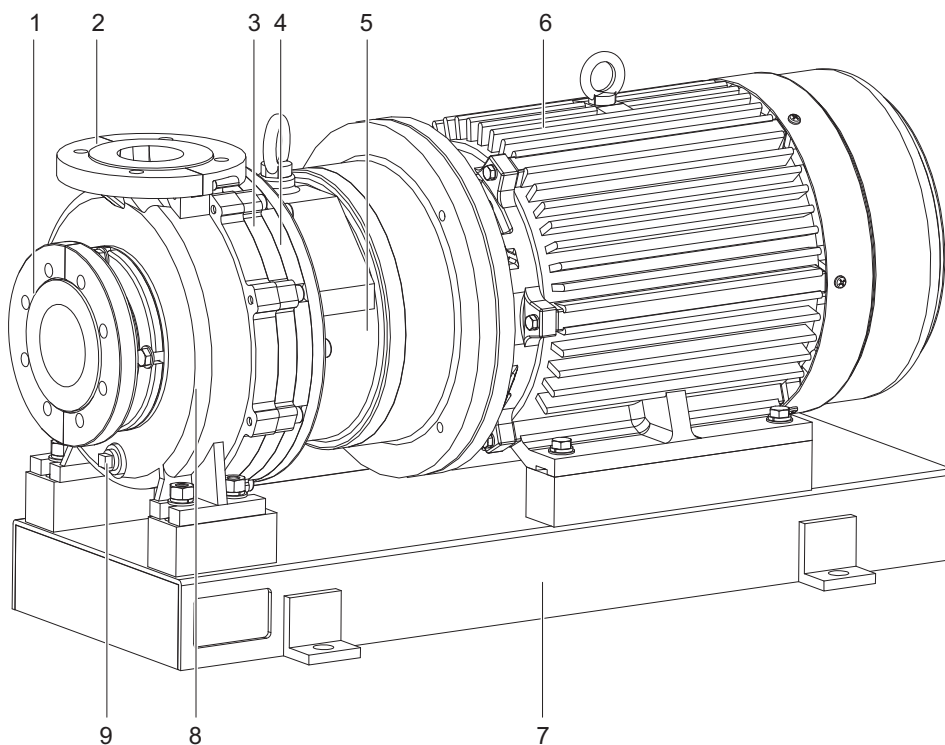

Fig. 3 Assembly

- | | | |
|--------------------------|------------------------------|-----------------------|
| 1 Suction flange | 4 Motor flange | 7 Base plate |
| 2 Pressure flange | 5 Magnetic coupling (hidden) | 8 Casing/casing armor |
| 3 Bearing frame assembly | 6 Motor | 9 Drain plug |

3.4 Magnetic coupling

Pumps with magnetic couplings are hermetically sealed and leaktight. Power transmission from the motor is non-contact through an enclosed and hermetically sealed rear cover on the impeller.

4 Transport, Storage and Disposal

4.1 Transport

 The user/owner is responsible for the transport of the pump.

 Weight specification (→ [9.3 Technical specifications, Page 35](#)).

4.1.1 Unpacking and inspection on delivery

1. Unpack the pump/machine drive on delivery, and inspect it for transport damage.
2. Check completeness and accuracy of delivery.
3. Ensure that the information on the name plate agrees with the order/design data.
4. Report any transportation damage to the manufacturer immediately.
5. Dispose of packaging material according to local regulations.

4.1.2 Lifting

 **DANGER**

Death or limbs crushed as a result transported items falling over!

- ▶ Use lifting gear appropriate for the total weight to be transported.
- ▶ Attach lifting gear in accordance with the following diagram.
- ▶ Do not stand under suspended loads.

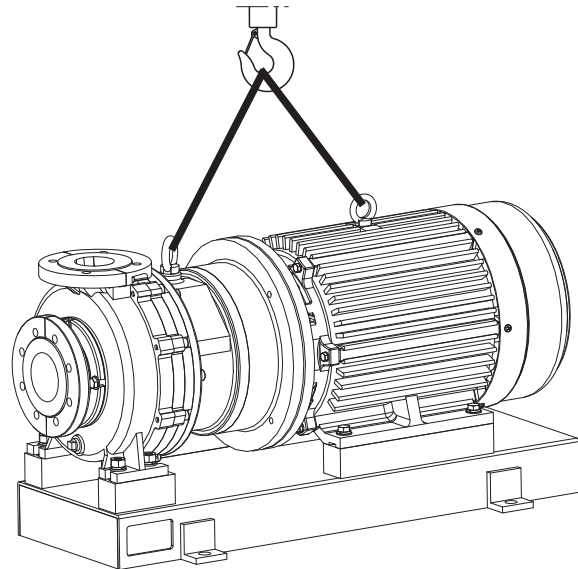

Fig. 4 Attach the lifting gear to the modular pump (illustration of general principle)

1. Attach lifting gear in accordance with the above diagram.
2. Lift the modular pump appropriately.

4.2 Storage

NOTE

Material damage due to inappropriate storage!

- ▶ Store the pump properly.
1. Rinse and empty the pump if necessary.
 2. Seal all openings with blind plugs or plastic covers.
 3. Make sure the storage room meets the following conditions:
 - Dry
 - Frost-free
 - Vibration-free
 - UV protected
 4. Rotate the pump shaft once a month.
 5. Make sure the shaft and bearing change their rotational position in the process.

4.3 Disposal

 Plastic parts can be contaminated by poisonous or radioactive pumped liquids to such an extent that cleaning will be insufficient.

WARNING

Risk of poisoning and environmental damage by the pumped liquid!

- ▶ Use personal protective equipment when carrying out any work on the pump.
 - ▶ Prior to the disposal of the pump:
 - Collect and damage any escaping pumped liquid in accordance with local regulations.
 - Neutralize residues of pumped liquid in the pump.
 - ▶ Remove plastic parts and damage them in accordance with local regulations.
-
- ▶ Dispose of the pump in accordance with local regulations.

5 Installation and connection

 For pumps in potentially explosive atmospheres (→ ATEX additional manual).

NOTE

Material damage caused by dirt!

- ▶ Do not remove the transport seals until immediately before installing the pump.
- ▶ Do not remove any covers or transport and sealing covers until immediately before connecting the pipes to the pump.

5.1 Preparing for installation

5.1.1 Check operating conditions

- ▶ Ensure the required operating conditions are met:
 - Resistance of body and seal material to the medium (→ resistance lists).
 - Required ambient conditions (→ 9.3.1 Ambient conditions, Page 35).

5.1.2 Preparing the installation site

- ▶ Ensure the installation site meets the following conditions:
 - Pump is freely accessible from all sides
 - Sufficient space for the installation/removal of the pipes and for maintenance and repair work, especially for the removal and installation of the pump
 - Pump not exposed to external vibration (damage to bearings)
 - Pump not exposed to external corrosive influences
 - Frost protection
 - The head of the pump is not exceeded.

5.1.3 Surface preparation

- ✓ Aids, tools, materials:
 - Spirit level
- ▶ Make sure the surface meets the following conditions:
 - Level and horizontal
 - Clean (no oil, dust or other impurities)
 - Capable of bearing the weight of the machine drive and all operating forces
 - Ensures the stability of the machine drive

5.2 Setting up

1. Lift up the machine drive (→ 4.1 Transport, Page 12).
2. Put down the machine drive at the place of installation.
3. Screw in and tighten the fixing screws on the base plate.

5.3 Planning pipelines

 Note the installation example (→ 9.2 Installation example, Page 34).

Water hammer may damage the pump or the system. Plan the pipes and fittings as far as possible to prevent water hammer occurring.

5.3.1 Designing pipelines

- ▶ Plan pipes safely:
 - No pulling or thrusting forces
 - No bending moments
 - Adjust for changes in length due to temperature changes (compensators, expansion shanks)
 - Avoid bends close to the pressure-side flange

5.3.2 Arranging the supports and connections

NOTE

Material damage due to excessive forces and torques on the pump!

- ▶ Ensure pipe connection without stress.
- ▶ Do not exceed the max. permissible tightening torque for the flange bolts (→ 9.3.4 Tightening torques, Page 35).

1. Support pipes in front of the pump.
2. Ensure the pipe supports will always allow expansion and contraction of the pipes.

5.3.3 Specifying nominal widths

 Keep the flow resistance in the pipes as low as possible.

1. Make sure the nominal suction line width is equal to the nominal suction flange width.
2. Make sure the nominal pressure line width is not smaller than the nominal discharge flange width.

5.3.4 Determine the pipe lengths and installation parameters

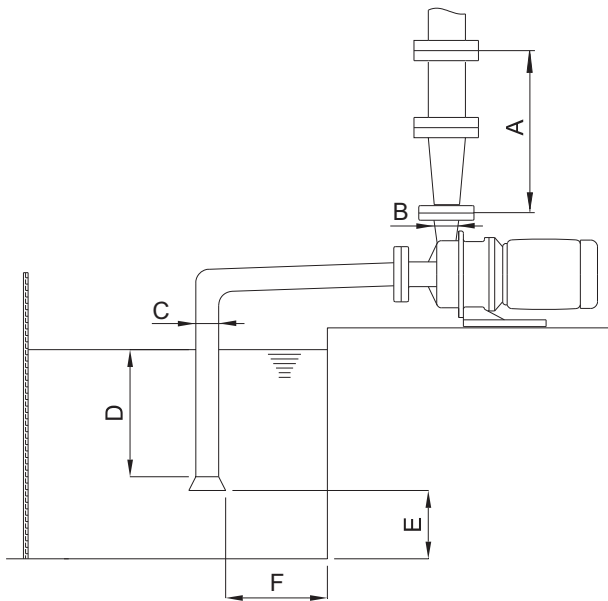



Fig. 5 Pipe lengths and installation parameters

- A > 5 x DNd
- B DNd
- C DN_s
- D > 0.5 m or > 2 x DN_s
- E > 1.5 x DN_s
- F > 1.5 x DN_s

1. Observe recommended minimum values when installing the pump. Note the installation example (→ [9.2 Installation example, Page 34](#)).

 | Pressure side: Shorter lengths are possible, but may result in increased noise development.

2. Note the normal-priming design of the pump (not self-priming).
3. Fill the pump and suction line completely with pumped liquid, and vent them before each start-up.
4. Maintain the required NPSH value of the pump (NPSH_r) at all times under the given system conditions.

5.3.5 Overview of installation conditions for pipelines

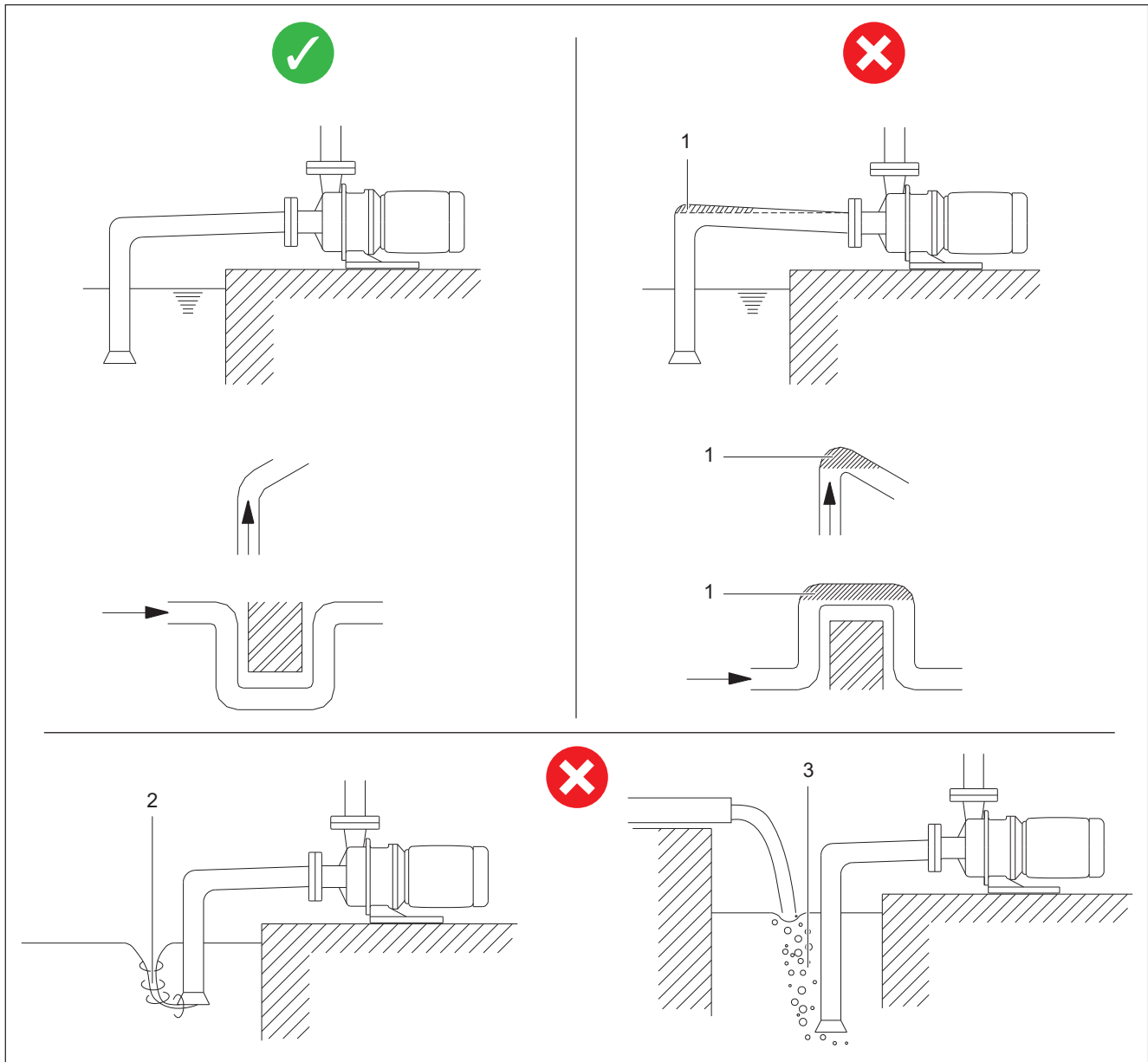

Fig. 6 Permissible (✓) and impermissible (X) installation conditions

- | | |
|--|------------------------------------|
| 1 Air pocket formation in the suction line | 3 Air bubbles in the pumped medium |
| 2 Vortex in the pumped medium | |

1. Comply with the installation conditions of the pipelines.
2. Note the normal-priming design of the pump (not self-priming).
3. Fill the pump and suction line completely with pumped liquid, and vent them before each start-up.
4. Maintain the required NPSH value of the pump (NPSH_r) at all times under the given system conditions.

5.3.6 Optimizing changes of cross section and direction

1. Avoid radii of curvature of less than 1.5 times the nominal pipe diameter.
2. Avoid abrupt changes of cross-section along the piping.

5.3.7 Providing safety and control devices (recommended)

Avoid contamination

- ▶ Install a dirt strainer with mesh size <3 mm at the inlet of the suction pipe.

Avoid reverse running

1. Install a foot valve or check valve between the pressure-side flange and shut-off valve to ensure that the medium does not flow back after the pump is switched off.
2. In order to enable venting, include vent connection between the pressure-side flange and foot valve or check valve.

Make provisions for isolating and shutting off the pipes

-  For maintenance and repair work.

- ▶ Provide shut-off valves in the suction pipe and pressure line.

Dry run protection by measuring the operating conditions

- ▶ Provide monitoring sensors for both pressure and flow rate, to protect the pump against dry running and consequential damage

5.4 Connecting the pipes

NOTE

Material damage due to excessive forces and torques on the pump!

- ▶ Ensure pipe connection without stress.

5.4.1 Keeping the piping clean

NOTE

Material damage due to impurities in the pump!

- ▶ Make sure no impurities can enter the pump.
-
- ▶ Clean all piping parts and fittings prior to assembly.

5.4.2 Installing suction pipe

1. Remove the transport and sealing covers from the pump.
2. Fit suction pipe stress-free and sealed.
3. Avoid gas cavities:
 - Always lay the suction pipe rising.
 - Install bends with an angle < 90°.
 - Do not install the suction pipe near whirlpools or supply lines.

5.4.3 Installing the pressure pipe

1. Remove the transport and sealing covers from the pump.
2. Align the pressure-side flange upwards to allow the pump head to be vented.
3. Fit the pressure line stress-free and sealed.
4. Install the foot valve under the following operating conditions:
 - Suction flow upwards
 - Negative pressure

5.4.4 Inspection for stress-free pipe connections

- ✓ Piping installed and cooled down
1. Disconnect the pipe connections from the pump.
 2. Check whether the pipes can be moved freely in all directions within the expected range of expansion.
 3. Make sure that the connections are parallel.
 4. Reconnect the pipe connections to the pump.

5.5 Electrical connection

 **DANGER**

Risk of electrocution!

- ▶ All electrical work must be carried out by qualified electricians only.
- ▶ Before all work on the electrical system, disconnect the motor from the mains and secure against being switched back on again.

5.5.1 Connecting the motor

-  Follow the instructions of the motor manufacturer.

1. Connect the motor according to the connection diagram.
2. Make sure no danger arises due to electric power.
3. Install an EMERGENCY STOP switch.

6 Operation

 For pumps in potentially explosive atmospheres (→ ATEX additional manual).

6.1 Preparing for commissioning

6.1.1 Check downtimes

- ▶ Before starting up the pump, check the downtime and perform the following actions:
 - Check the fill level.
 - If the hydraulic parts are dirty, clean them.
 - Check that the impeller runs freely.

6.1.2 Filling and bleeding

1. Open the suction-side fitting.
2. Open the pressure-side fitting.
3. Fill pump and suction pipe with fluid.
4. Verify that no pipe connections are leaking.

6.1.3 Check direction of rotation

NOTE

Material damage as a result of dry running!

- ▶ Make sure the pump is filled properly.
1. Switch on motor for max. 2 seconds and switch it off again immediately.
 2. Visually check the direction of rotation of the motor fan impeller and make sure that the direction of rotation of the motor matches the direction arrow on the pump casing.
 3. If the sense of rotation is different: Change over the two phases (→ [5.5 Electrical connection, Page 17](#)).

6.2 Commissioning

6.2.1 Switching on

- ✓ Pump set up and connected properly
- ✓ Motor set up and connected properly
- ✓ All connections stress-free and sealed
- ✓ All safety equipment installed and tested for functionality
- ✓ Pump prepared, filled and vented correctly
- ✓ Tank fill sufficient

NOTE

Risk of cavitation if suction flow is restricted!

- ▶ Open the suction-side fitting and do not use it to regulate the flow, if installed.
- ▶ Do not open the pressure-side fitting beyond the operating point.

NOTE

Material damage due to overheating!

- ▶ Do not operate the pump for long periods with the pressure-side fitting closed.
- ▶ Observe the minimum flow rate (→ [9.3.8 Minimum volume flow, Page 37](#)).

NOTE

Material damage as a result of dry running!

- ▶ Make sure the pump is filled properly.
1. Open the suction-side fitting, if installed.
 2. Close the pressure-side fitting.
 3. Open the exhaust line fitting.
 4. Switch on the motor and check it for smooth running.
 5. Make sure that the suction pipe and pump are vented fully. Check the vacuum gauge.
Gas escapes through the exhaust line.
 6. Once as the suction line is vented, close the vent line and slowly open the pressure-side valve.
 7. Make sure temperature change is smaller than 5 K/min for pumps with hot fluids.
 8. After the initial stress due to the pressure and operating temperature, check that the pump is not leaking.
 9. If leaks are present at the housing seals or flanges, proceed as follows:
 - Switch off motor.
 - Close the control valves.
 - Remedy the leaks.

6.2.2 Switching off

- ✓ Pressure-side fitting closed (recommended)
1. Switch off motor.
 2. Check all connecting screws and tighten them to the specified torque (→ [9.3.4 Tightening torques, Page 35](#)).

6.3 Shutting down the pump

- ▶ Take the following measures whenever the pump is shut down:

Pump is	Measure
shut down	▶ Take measures appropriate for the fluid (→ Tab. 5 Measures depending on the behavior of the pumped liquid, Page 19).
...emptied	▶ Close suction and pressure-side fitting.
...dismounted	▶ Isolate the motor from its power supply and secure it against unauthorized switch-on.
...put into storage	▶ Note measures for storage (→ 4.2 Storage, Page 12).

Tab. 4 Measures to be taken if the pump is shut down

Behavior of the pumped liquid	Duration of shutdown (depending on process)	
	Short	Long
Crystallized or polymerized, solids sedimenting	▶ Flush the pump.	▶ Flush the pump.
Solidifying/ freezing, non-corrosive	▶ Heat up or empty the pump and containers.	▶ Empty the pump and containers.
Solidifying/ freezing, corrosive	▶ Heat up or empty the pump and containers.	▶ Empty the pump and containers.
Remains liquid, non-corrosive	–	–
Remains liquid, corrosive	–	▶ Empty the pump and containers.

Tab. 5 Measures depending on the behavior of the pumped liquid

6.4 Restoring the pump to service

- ▶ Complete all steps as for commissioning (→ [6.2 Commissioning, Page 18](#)).

6.5 Operating the stand-by pump

- ✓ Stand-by pump filled and bled
- ✓ Suction pipe not vented

 Operate the stand-by pump at least once a week.

1. Fully open the suction-side fitting, if installed.
2. Open pressure-side fitting far enough so that the stand-by pump operating temperature is achieved and heating is even (→ [6.2.1 Switching on, Page 18](#)).

7 Maintenance

Opening the pump casing invalidates the warranty.

When used for the intended purpose the bearings and seals are virtually free of wear and will not require replacement during the warranty period.

Maintenance and repair work should be undertaken in consultation with Schmitt Kreiselpumpen. The chapter describes maintenance not within the warranty period.

 For pumps in potentially explosive atmospheres (→ ATEX additional manual).

 Maintenance during the warranty period will be performed by Schmitt Kreiselpumpen. Submit evidence of conveyed medium on request (DIN safety data sheet or confirmation of decontamination).

7.1 Inspections

 The inspection intervals depend on the operational strain on the pump.

1. Check at appropriate intervals:
 - Adherence to the minimum flow rate
 - Normal operating conditions unchanged
 - Tank fill level
2. For trouble-free operation, always ensure the following:
 - No dry running
 - No leaks
 - No cavitation
 - Shut-off valve open on the suction side, if installed
 - Free and clean filters
 - Sufficient pump inlet pressure
 - No unusual running noises or vibrations
 - No parting of magnetic coupling

7.2 Servicing

 Plain bearings are subject to natural wear and tear which is heavily dependent on the respective operating conditions. It is therefore not possible to make general statements about the operating life.

Inspection and replacement of the plain bearings is performed when the pump is disassembled (→ [7.3.2 Disassembling and checking the pump, Page 21](#)).

7.2.1 Maintenance in accordance with maintenance schedule

- ▶ Perform maintenance work in accordance with the maintenance schedule (→ [9.4 Maintenance schedule, Page 38](#)).

7.2.2 Cleaning the pump

NOTE

High water pressure or spray water can cause material damage!

- ▶ Do not direct water jets or steam jets into the opening of the flange.
- ▶ Regularly clean the pump to remove heavy dirt.

7.3 Dismounting

WARNING

Risk of injury due to heavy components!

- ▶ Pay attention to the component weight. Lift and transport heavy components using suitable lifting gear.
- ▶ Set down components safely and secure them against overturning or rolling away.

WARNING

Risk of injury during disassembly!

- ▶ Secure the pressure-side shut-off valve against accidental opening.
- ▶ Wear protective gloves, components can become very sharp-edged due to wear or damage.
- ▶ Observe the manufacturer's specifications (e.g. for the motor).

NOTE

Material damage due to incorrect dismounting/installation of the pump!

- ▶ Only specialist mechanics should complete dismounting/installation work.

7.3.1 Preparations for dismounting

- ✓ Pump is depressurized
 - ✓ Pump completely empty, flushed and decontaminated
 - ✓ Electrical connections disconnected and motor secured against switch-on
 - ✓ Pump cooled down
 - ✓ Pressure gauge lines, pressure gauge and fixtures dismounted
1. Dismantle the pipes on the suction and pressure side.
 2. Remove pump from the system.
 3. When dismounting, observe the following:
 - Mark the precise orientation and position of all components before dismounting them.
 - Dismount components concentrically without canting.

7.3.2 Disassembling and checking the pump

Following the drawings for disassembly (→ 9.1.2 Drawings, Page 30).

Request spare parts from the manufacturer (→ 7.4 Replacement parts and return, Page 23).

During disassembly, stressed parts are checked for damage and replaced if necessary:

- Bearing rings, bearings, plain bearings
- Impeller
- Shaft
- Seal and O-ring

The plain bearings consist of the following parts. The arrangement and number of bearing rings depends on the size:

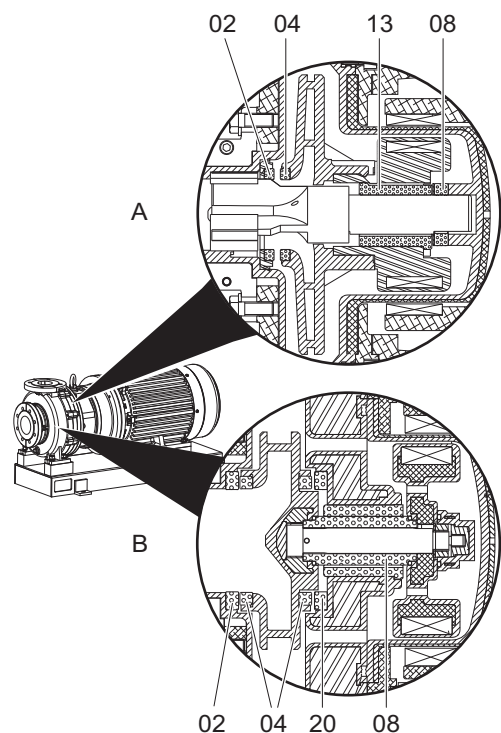

Fig. 7 Components of the plain bearings

- A Sizes 50-32-200 and 65-50-160
- B Sizes 65-40-200 and 80-65-160
- 02 Bearing ring (housing)
- 04 Bearing ring (impeller assembly)
- 08 Bearing (B) or rear thrust collar (A)
- 13 Plain bearing
- 20 Bearing ring (bearing frame assembly)

- ✓ Prepared for disassembly.

NOTE

Material damage, fragile components!

The plain bearings can be damaged.

- ▶ Perform disassembly carefully, and do not strike or knock the fragile parts of the plain bearing.

For sizes 50-32-200 and 65-50-160, dismantle and check stressed parts

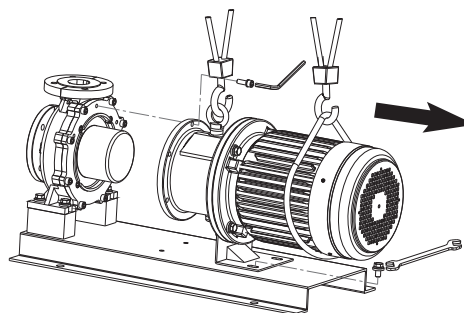

1. Unscrew the hexagon socket screws from the motor flange adapter (09).
2. Unscrew the hexagon head screws from the support (17) and the base plate (16).
3. Attach the motor flange adapter (09) and motor to a hoist.
4. Pull off adapter motor flange (09) with motor in the direction of the arrow and put it aside in a safe place.

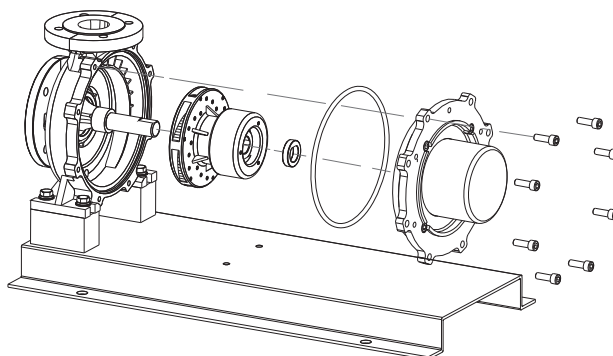

5. Unscrew the hexagon socket screws from the carrier plate (06).
6. Remove the carrier plate (06) with the containment shell (14).
7. Remove the flat gasket (12).
8. Remove the rear thrust collar (08).
9. Carefully remove the impeller assembly (04) from the shaft (11).
10. For size 50-32-200, remove the following parts from the shaft (11):
 - Front stop with front bearing ring
 - Front shaft bracket

11. Check the stressed parts for damage and replace them if necessary:
 - Bearing rings, plain bearings
 - Impeller
 - Shaft
12. Check stressed parts for wear. Replace parts if they exceed the wear limits (→ 9.3.5 Wear limits, Page 36).
13. Continue as required:
 - If no further disassembly is required, install the stressed parts (→ 7.5 Installing, Page 24).
 - Completely dismantle the pump (→ Dismount the pump, Page 23).

For sizes 65-40-200 and 80-65-160, dismantle and check the stressed parts

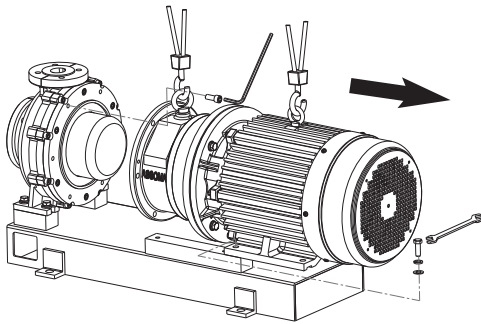

1. Unscrew the hexagon socket screws from the motor flange (12).
2. Unscrew the hexagon head screws from the motor base and the base plate (24).
3. Attach the motor flange (12) and motor to a hoist.
4. Pull off the motor flange (12) with motor in the direction of the arrow and put it aside in a safe place.

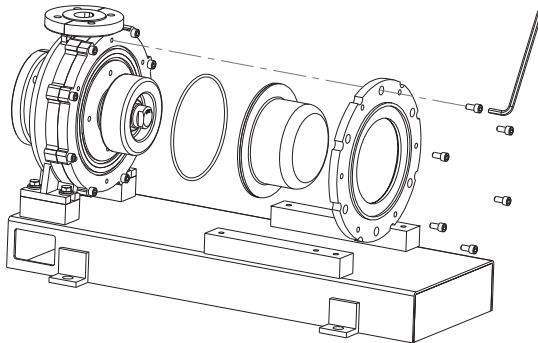

5. Unscrew the hexagon socket screws from the carrier plate (22).
6. Remove the carrier plate (22).
7. Remove the containment shell (14).
8. Remove the seal (18).

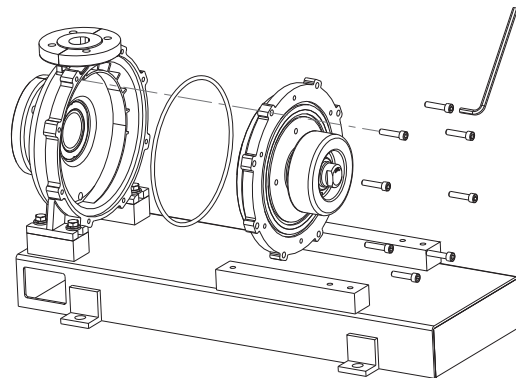

9. Unscrew the hexagon socket screws from the bearing frame assembly (20).
10. Remove the bearing frame assembly (20) together with the impeller assembly (04), shaft (15) and shaft sleeve (07).
11. Remove the seal (21).

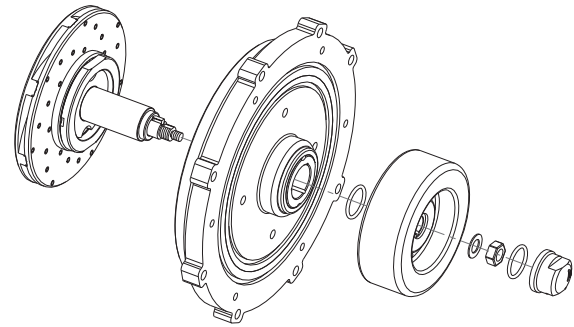

12. Unscrew the shaft cover (16) clockwise.
13. Remove the seal (23).
14. Unscrew the nut with washer (11).
15. Remove the magnetic capsule (10).
16. Remove the seal (09).
17. Remove the impeller assembly (04), shaft (15) and shaft sleeve (07) from the bearing frame (20).
18. Pull the shaft sleeve (07) off the shaft (15).
19. Check the stressed parts for damage and replace them if necessary:
 - Bearing rings, plain bearings
 - Impeller
 - Shaft
20. Check stressed parts for wear. Replace parts if they exceed the wear limits (→ 9.3.5 Wear limits, Page 36).
21. Continue as required:
 - If no further disassembly is required, install the stressed parts (→ 7.5 Installing, Page 24).
 - Completely dismantle the pump (→ Dismount the pump, Page 23).

Dismount the pump

1. For sizes 50-32-200 and 65-50-160, remove the support plate (06) from the containment shell (14).
2. Unscrew the hexagon head screws with washers from the housing and base plate (16 or 24).
3. Remove the housing from the base plate (16 or 24).
4. Unscrew the drain plug (10 or 19).
5. For sizes 50-32-200 and 65-50-160, remove the motor flange adapter (09):
 - Unscrew the hexagon head screws with washers from the motor flange adapter (09) and motor.
 - Remove the motor flange adapter (09) from the motor.
 - Unscrew the support (17).
6. For sizes 65-40-200 and 80-65-160, remove the motor flange (12):
 - Unscrew the hexagon head screws with washers from the motor flange adapter (13) and motor.
 - Remove the motor flange (12) from the motor using the motor flange adapter (13).
 - Remove the motor flange (12) from the motor flange adapter (13).
7. Loosen the grub screw on the drive magnet (15 or 17).
8. Pull the drive magnet (15 or 17) off the motor shaft.
9. Remove the feather key.
10. Check that the through holes and relief holes are not blocked - if they are, clean them.

7.4 Replacement parts and return

1. Have the following information as shown on the name plate ready to hand when ordering spare parts (→ 3.1 Marking, Page 10).
 - Article numbers
 - Type
 - Year of manufacture
2. Please complete and enclose the confirmation of decontamination for returns (→ www.schmitt-pumpen.de/sites/default/files/2020-10/Dekontaminationsnachweis_en.pdf).



3. Use only spare parts from SCHMITT (E-Mail: sales@schmitt-pumpen.de).

7.5 Installing

 Install components concentrically and without tilting in accordance with the markings applied.

WARNING

Risk of injury due to heavy components!

- ▶ Pay attention to the component weight. Lift and transport heavy components using suitable lifting gear.
- ▶ Set down components safely and secure them against overturning or rolling away.

WARNING

Risk of injury during assembly!

- ▶ Observe the manufacturer's specifications (e.g. for the motor).

NOTE

Material damage due to incorrect dismantling/installation of the pump!

- ▶ Only specialist mechanics should complete dismantling/installation work.

NOTE

Material damage due to unsuitable components!

- ▶ Always replace lost or damaged screws with screws of the same strength where required.
- ▶ Only replace seals with seals of the same material.

NOTE

Material damage, fragile components!

- ▶ Install ceramic parts of the plain bearing and magnets of the magnetic coupling with care, do not strike them or knock them.

7.5.1 Preparations for installation

- ▶ When installing please observe:
 - Replace worn parts with genuine spare parts.
 - Replace the seals and insert them so that they cannot twist.
 - Do not apply synthetic or mineral oil, grease or cleaning agents to elastomer components.
 - Install components concentrically and without tilting in accordance with the markings applied.

7.5.2 Assembly of the pump

 Following the drawings for assembly (→ [9.1.2 Drawings, Page 30](#)).

If only stressed parts have been disassembled and tested, the steps in the section „Assembling the pump“ can be omitted.

- ✓ Prepared for installation.

Installing the pump

1. Align the drive magnet (15 or 17) with the tapped hole to the feather key and slide it on to the motor shaft. Align the drive magnet parallel to the shaft end.
2. Screw in the grub screw and fix the drive magnet. Observe the correct torque.
3. For sizes 50-32-200 and 65-50-160, fit the motor flange adapter (09):
 - Tighten the support (17).
 - Align the motor flange (09) correctly to the motor and install.
 - Screw the motor flange (09) to the motor using the hexagon head screws and washers. Tighten the hexagon head screws crosswise and observe the correct torque (→ [9.3.4 Tightening torques, Page 35](#)).
4. For sizes 65-40-200 and 80-65-160, fit the motor flange (12):
 - Fit the motor flange adapter (13) to the motor flange (12).
 - Align the motor flange (12) correctly to the motor using the motor flange adapter (13) and install.
 - Screw the motor flange adapter (13) to the motor using the hexagon head screws and washers. Tighten the hexagon head screws crosswise and observe the correct torque (→ [9.3.4 Tightening torques, Page 35](#)).
5. Screw the drain plug (10 or 19) into the housing.
6. Place the housing on the base plate (16 or 24) and secure it using the hexagon head screws.
7. For sizes 50-32-200 and 65-50-160, fit the containment shell (14) to the support plate (06):
8. Continue assembly of the stressed parts depending on the size:
 - (→ [Mounting stressed parts for sizes 50-32-200 and 65-50-160, Page 24](#)).
 - (→ [Mounting stressed parts for sizes 65-40-200 and 80-65-160, Page 25](#)).

Mounting stressed parts for sizes 50-32-200 and 65-50-160

1. For size 50-32-200, fit the following parts to the shaft (11):
 - Front shaft bracket
 - Front stop with front bearing ring
2. Carefully slide the impeller assembly (04) on to the shaft (11).
3. Fit the pressure ring at the rear (08).
4. Fit the flat gasket (12) into the containment shell (14).
5. Fit the support plate (06) with the containment shell (14) to the housing and screw tight with the hexagon socket screws.
6. Attach the motor flange adapter (09) and motor to a hoist.

7. Fit the motor flange adapter (09) with motor to the support plate (06) and place it on the base plate (16).
8. Screw the motor flange adapter (09) to the support plate (06) using the hexagon socket screws.
9. Screw the support (17) to the base plate (16) using the hexagon head screws.
10. Remove the hoist.

Mounting stressed parts for sizes 65-40-200 and 80-65-160

1. Push the shaft sleeve (07) on to the shaft (15).
2. Fit the impeller assembly (04), shaft (15) and shaft sleeve (07) into the bearing frame (20).
3. Fit the seal (09).
4. Fit the magnetic capsule (10).
5. Tighten the nut with the washer (11).
6. Fit the seal (23).
7. Tighten the shaft cover (16) counterclockwise.
8. Fit the seal (21) into the bearing frame (20).
9. Fit the bearing frame (20) with impeller assembly (04), shaft (15) and shaft sleeve (07) to the housing and tighten with the hexagon socket screws.
10. Fit the seal (18) into the containment shell (14).
11. Mount the carrier plate (22) on the containment shell (14)
12. Fit the carrier plate (22) with the containment shell (14) on to the bearing frame (20) and secure it with the hexagon socket screws.
13. Attach the motor flange (12) and motor to a hoist.
14. Mount the motor flange (12) with motor on the support plate (22) and place it on the base plate (24)
15. Screw the motor flange (12) to the support plate (22) using the hexagon socket screws.
16. Screw the motor base to the base plate (24) using the hexagon head screws.
17. Remove the hoist.

7.5.3 Install the pump into the system

- ▶ Install the pump in the system. (→ [5 Disposal, Page 14](#)).

8 Troubleshooting

If faults occur which are not specified in the following table or cannot be traced back to the specified causes, please consult the manufacturer.

Possible faults are identified by a fault number in the table below. This number identifies the respective cause and remedy in the troubleshooting list.

Fault	Number
Pump not pumping	1
Pumping rate insufficient	2
Pumping rate excessive	3
Pumping pressure insufficient	4
Pumping pressure excessive	5
Pump running roughly / loud noises / vibration	6
Pump leaks	7
Excessive motor power uptake	8
Housing temperature too high	9

Tab. 6 Fault/number assignment

Fault number									Cause	Remedy
1	2	3	4	5	6	7	8	9		
X	-	-	-	-	-	-	-	-	Suction pipe and/or pressure line closed by fitting	► Open the fitting.
X	-	-	-	-	-	-	-	-	Transport and sealing cover still in place	► Remove the transport and sealing cover. ► Dismount the pump and inspect it for dry-running damage.
X	X	-	-	-	-	-	-	-	Suction pipe too long	► Shorten suction pipe.
X	X	-	-	-	-	-	-	-	Pump flange deformed or damaged	► Change the pump flange.
X	X	-	X	-	-	-	-	-	Motor speed too low	► Compare the required motor speed with the specifications on the pump type plate. Replace the motor if necessary. ► Increase the motor speed if speed control is available.
X	X	-	X	-	-	-	-	-	Magnetic coupling has parted	► Switch off pump and switch on again.
X	X	-	X	-	X	-	-	-	Intake / suction pipe, pump or suction strainer blocked or encrusted	► Clean intake/suction pipe, pump or suction strainer.
X	X	-	X	-	X	-	-	-	Air is sucked in	► Seal source of problem.
X	X	-	X	-	X	-	-	-	Proportion of gas too high: pump is cavitating	► Consult the manufacturer.
X	X	-	X	-	X	-	-	-	Pump running in the wrong direction	► Change over any two phases in the motor.
X	X	-	X	-	X	-	-	-	Impeller out of balance or blocked	► Dismount the pump and inspect it for dry-running damage. ► Clean the impeller.
X	X	-	-	X	X	-	-	-	Pressure pipe blocked	► Clean the pressure pipe.

Fault number									Cause	Remedy
1	2	3	4	5	6	7	8	9		
X	-	-	-	-	X	-	-	-	Suction pipe and pump not correctly vented or not completely filled	▶ Completely fill and vent pump and/or pipe.
X	-	-	-	-	-	-	-	X	Standstill, plain bearing stuck	▶ Disassemble the pump and carefully free the plain bearing rings.
-	X	-	X	-	X	-	-	-	Cross section of suction pipe too narrow	▶ Increase cross section. ▶ Clean encrustation from suction pipe. ▶ Fully open the fitting, if installed.
-	X	-	X	-	X	-	-	-	Hydraulic parts of the pump dirty, clotted or encrusted	▶ Dismount the pump. ▶ Clean the parts.
-	X	-	X	-	X	-	-	-	Suction head too large: $NPSH_{pump}$ is larger than $NPSH_{system}$	▶ Increase pump inlet pressure. ▶ Consult the manufacturer.
-	X	-	X	-	X	-	-	-	Back pressure of the system is too high, pump selected is too small.	▶ Consult the manufacturer.
-	X	-	X	-	X	-	-	-	Pump parts worn	▶ Replace the worn pump parts.
-	X	-	X	-	X	-	-	-	Pump jammed	▶ Consult the manufacturer.
-	X	-	X	-	X	-	X	-	Motor running on 2 phases	▶ Check the fuse and replace it if necessary. ▶ Check the cable connections and insulation.
-	X	-	X	-	X	-	-	X	Temperature of fluid is too high: pump is cavitating	▶ Increase pump inlet pressure. ▶ Lower temperature. ▶ Contact the manufacturer.
-	X	-	X	-	-	-	X	X	Viscosity or specific gravity of the pumped liquid outside the range specified for the pump	▶ Consult the manufacturer.
-	X	-	X	-	-	-	-	X	Geodetic differential head and/or pipe flow resistances too high	▶ Remove sediments from the pump and/or pressure pipe. ▶ Install a larger impeller and consult the manufacturer. ▶ Reduce the system pressure.
-	X	-	-	X	X	-	-	-	Pressure-side fitting not opened wide enough	▶ Open the pressure-side fitting.
-	-	X	X	-	X	-	X	-	Pressure-side fitting opened too wide	▶ Throttle down at the pressure-side fitting. ▶ Machine the impeller down. Consult the manufacturer and adjust the impeller diameter.
-	-	X	-	X	-	-	-	-	Viscosity lower than expected	▶ Machine the impeller down. Consult the manufacturer and adjust the impeller diameter.
-	-	X	-	X	X	-	X	-	Motor speed too high	▶ Compare the required motor speed with the specifications on the pump type plate. Replace the motor if necessary. ▶ Reduce the motor speed if speed control is available.

Fault number									Cause	Remedy
1	2	3	4	5	6	7	8	9		
-	-	X	-	X	X	-	X	-	Impeller diameter too large	<ul style="list-style-type: none"> ▶ Throttle down the flow rate at the pressure-side fitting. Observe the minimum flow rate. ▶ Machine the impeller down. Consult the manufacturer and adjust the impeller diameter.
-	-	X	-	-	X	-	X	-	Geodetic differential head, pipe flow resistances and/or other resistances lower than specified	<ul style="list-style-type: none"> ▶ Throttle down the flow rate at the pressure-side fitting. Observe the minimum flow rate. ▶ Machine the impeller down. Consult the manufacturer and adjust the impeller diameter.
-	-	-	-	-	X	X	X	-	Pump distorted	<ul style="list-style-type: none"> ▶ Check the pipe connections and pump attachment.
-	-	-	-	-	X	-	-	-	Pipes and fittings blocked	<ul style="list-style-type: none"> ▶ Disassemble and clean the pipes and fittings.
-	-	-	-	-	X	-	X	-	Plain bearing faulty	<ul style="list-style-type: none"> ▶ Change the plain bearing (→ 7.3.2 Disassembling and checking the pump, Page 21).
-	-	-	-	-	-	X	-	-	Connecting bolts not correctly tightened	<ul style="list-style-type: none"> ▶ Check all connecting screws and tighten them to the specified torque (→ 9.3.4 Tightening torques, Page 35).
-	-	-	-	-	-	X	-	-	Faulty housing seal	<ul style="list-style-type: none"> ▶ Replace the housing seal.

Tab. 7 Troubleshooting list

9 Appendix

9.1 Parts

9.1.1 Part numbers and designations

Sizes 65-40-200 and 80-65-160

Part no.	Designation
01	Inlet armor
02	Casing, wetted by the pumped liquid
03	Casing armor
04	Impeller assembly
05	Outlet armor
06	Seal
07	Shaft sleeve
08	Bearing
09	Seal
10	Magnetic capsule
11	Nut & washer
12	Motor flange
13	Motor flange adapter
14	Rear cover
15	Shaft
16	Shaft cover
17	Drive magnet
18	Seal
19	Drain plug
20	Bearing frame assembly
21	Seal
22	Carrier plate
23	Seal
24	Base plate

Tab. 8 Naming of components by part number, sizes 65-40-200 and 80-65-160

Sizes 50-32-200 and 65-50-160

Part no.	Designation
01 ¹⁾	Inlet armor
02	Casing, wetted by the pumped liquid
03	Front outlet casing armor
04	Impeller assembly
05	Rear outlet casing armor
06	Carrier plate
07	Magnetic capsule
08	Rear pressure ring
09	Motor flange adapter
10	Drain plug
11	Shaft
12	Flat gasket
13	Plain bearing
14	Rear cover
15	Drive magnet
16	Base plate
17	Support

Tab. 9 Naming of components by part number, sizes 50-32-200 and 65-50-160

9.1.2 Drawings
Sectional drawings

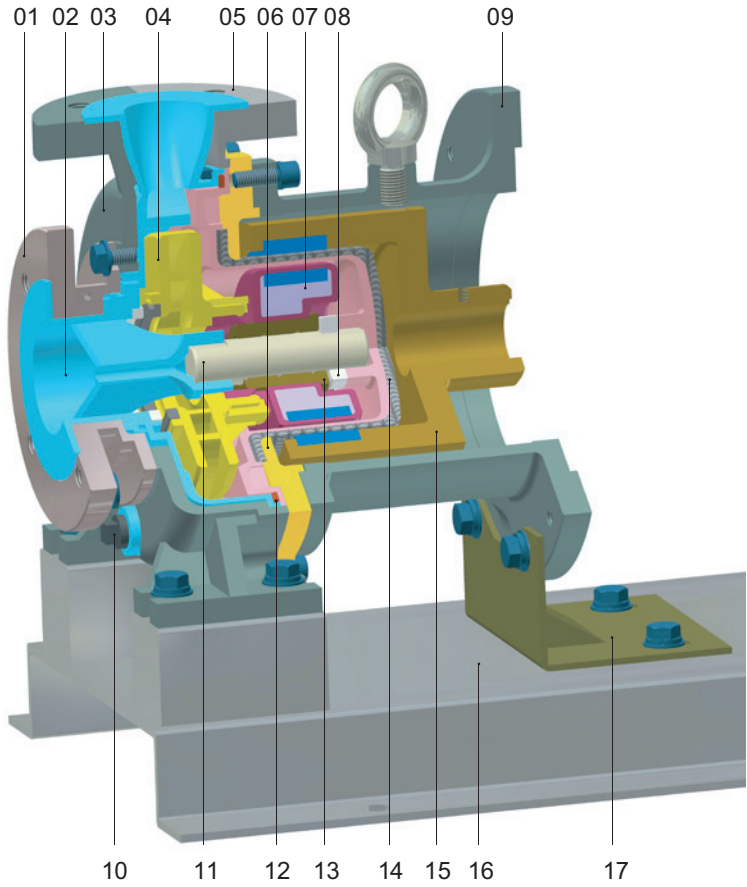

Fig. 8 Parts (sectional drawing), sizes 50-32-200 and 65-50-160

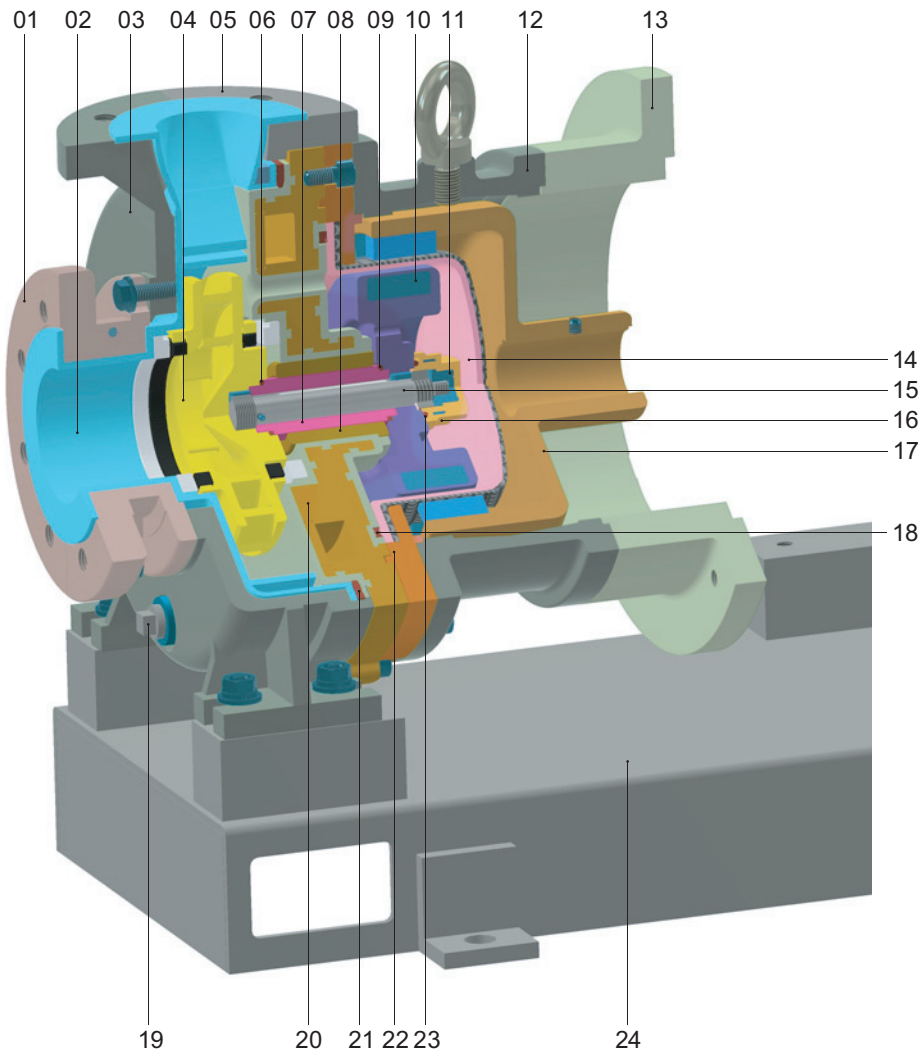

Fig. 9 Parts (sectional drawing), sizes 65-40-200 and 80-65-160

Exploded drawings

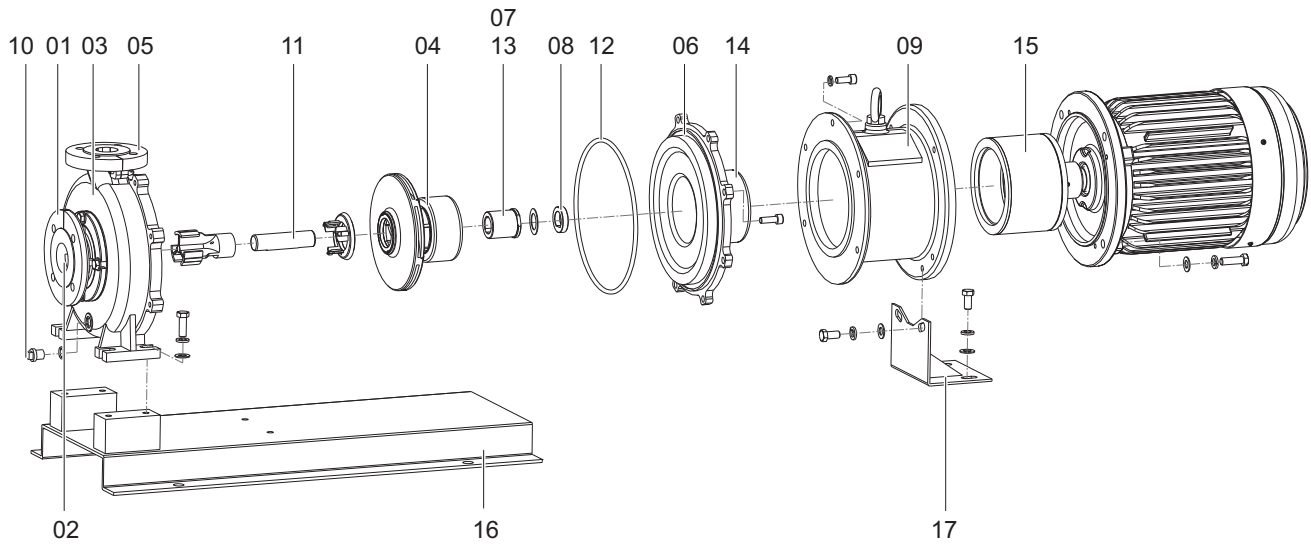

Fig. 10 Parts (exploded view), size 50-32-200

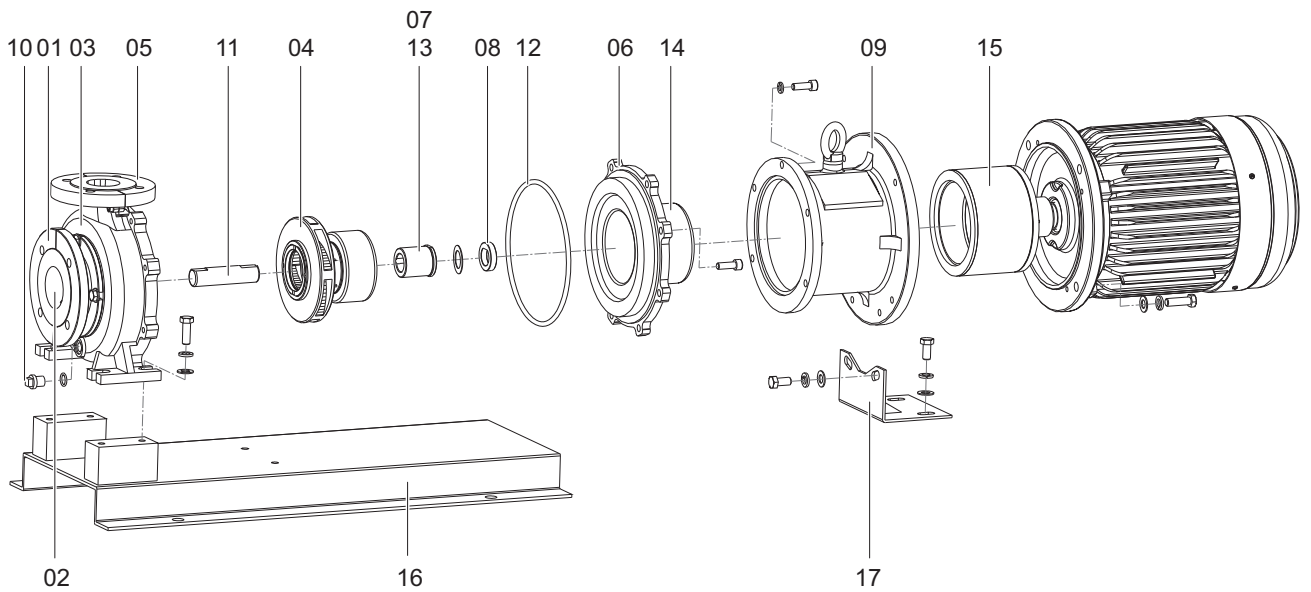

Fig. 11 Parts (exploded view), size 65-50-160

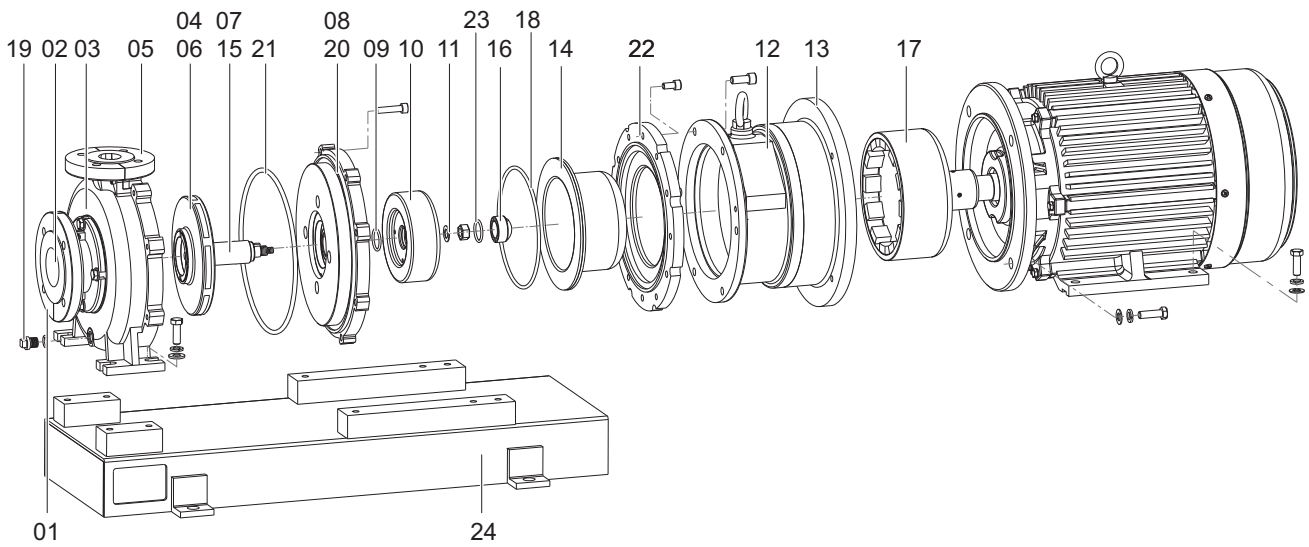

Fig. 12 Parts (exploded view), size 65-40-200

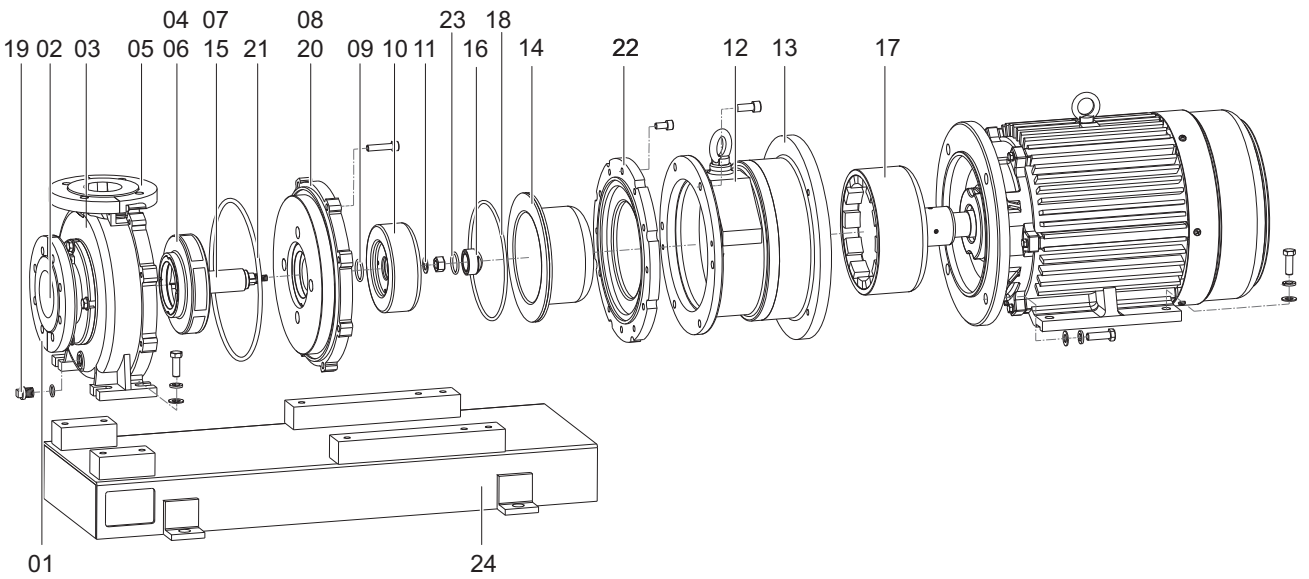

Fig. 13 Parts (exploded view), size 80-65-160

9.2 Installation example

The following example pipe schematic shows the main components of a pump installation.

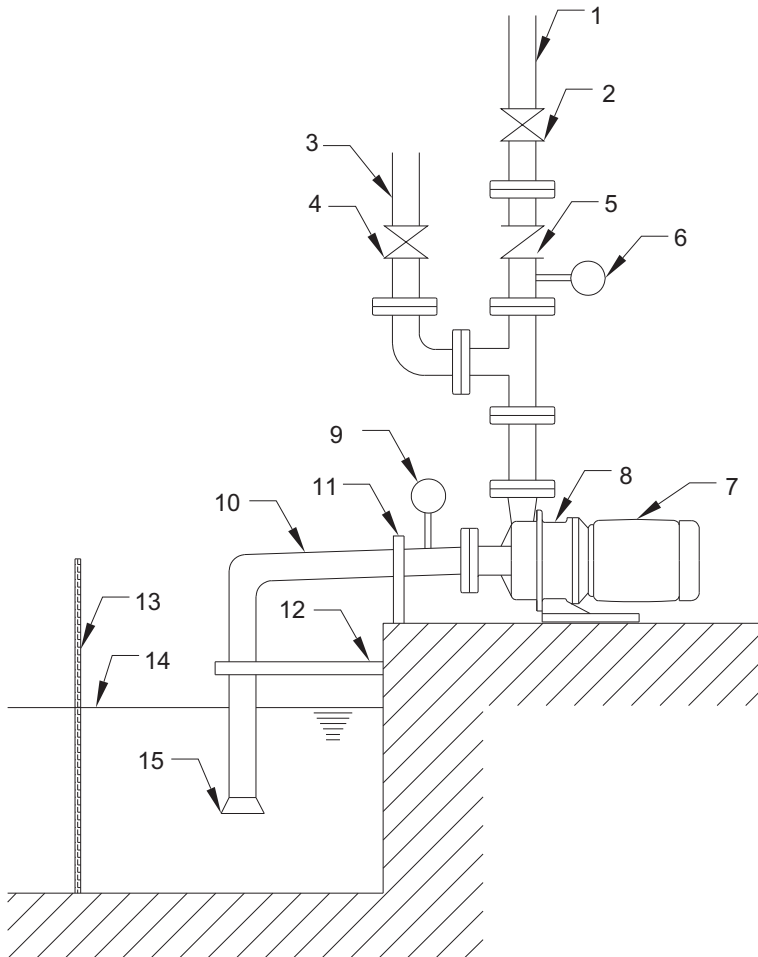



Fig. 14 Installation example

- | | | |
|--------------------------------|--------------------------------|-------------------------|
| 1 Pressure line | 6 Pressure side pressure gauge | 11 Suction line bracket |
| 2 Pressure line shut-off valve | 7 Motor | 12 Vibration damper |
| 3 Filling line | 8 Pump | 13 Filter |
| 4 Filling line shut-off valve | 9 Suction side pressure gauge | 14 Tank |
| 5 Non-return valve | 10 Suction pipe | 15 Foot valve |

9.3 Technical specifications

9.3.1 Ambient conditions

 Operation under any other ambient conditions should be agreed with the manufacturer.

Temperature [°C]	Relative humidity [%]		Installation height above sea level [m]
	Long-term	Short-term	
5 to +40 ¹⁾	≤ 85	≤ 100	≤ 1000

Tab. 10 Ambient conditions

1) material-dependent

9.3.2 Total pressure

 Total pressure = system pressure + pressure build-up in the pump

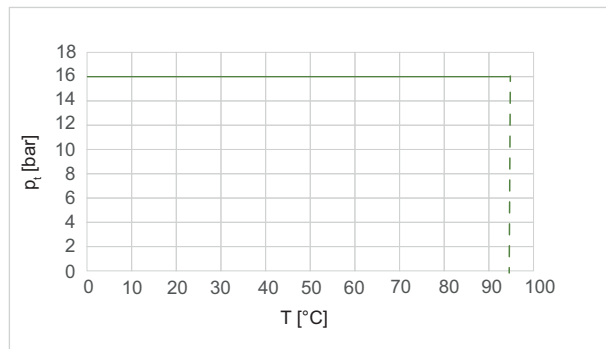

Fig. 15 Total pressure

9.3.3 Sound pressure level

Motor power rating [kW]	Sound pressure level [dB(A)]
5.5...11	82
11...18.5	85

Tab. 11 Sound pressure level

Measuring conditions:

- Distance to the pump: 1 m
- Operation: cavitating, gate valve fully open
- Tolerance ±3 dB

9.3.4 Tightening torques

Comply with the following tightening torques and use a torque wrench:

Housing

Thread size	Tightening torque [Nm]
M6	5
M10	25
M12	45
1/2"	45

Tab. 12 Tightening torques for the housing

Suction flange and pressure flange

Thread size	Tightening torque [Nm]
M12	45
M16	70

Tab. 13 Tightening torques for the suction flange and pressure flange

9.3.5 Wear limits

Wear limits of individual parts

The manufacturer recommends replacing the part when it reaches the wear limit.

Size NEOChem ...	Part (measurement)	Dimension [mm]	
		New	Wear limit
50-32-200 65-50-160	Shaft (outer diameter)	28	27.4
	Bearing (inner diameter)	28	28.6
	Bearing ring, thrust ring (thickness)	7	6
65-40-200 80-65-160	Shaft (outer diameter)	38	37.4
	Bearing (inner diameter)	38	38.6
	Bearing ring, thrust ring (thickness)	10	9

Tab. 14 Wear limits

Total wear between individual parts

If the following total wear limit is exceeded, the manufacturer recommends replacing the part with the greater wear:

- Bearing and shaft > 0.6 mm
- Bearing ring (housing) and bearing ring (impeller) > 1 mm

9.3.6 Permissible forces and torques on the suction flange and pressure flange

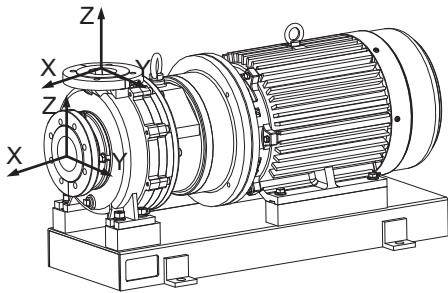

Fig. 16 Forces and torques on the suction flange and pressure flange

Size NEOChem ...	Suction flange							
	Forces [N]				Torques [Nm]			
	F _x	F _y	F _z	ΣF	M _x	M _y	M _z	ΣM
50-32-200	580	530	470	900	490	350	400	720
65-40-200	740	650	600	1100	530	380	420	770
65-50-160	740	650	600	1100	530	380	420	770
80-65-160	790	720	880	1300	560	400	460	820

Tab. 15 Forces and torques on the suction flange

Size NEOChem ...	Pressure flange							
	Forces [N]				Torques [Nm]			
	F _x	F _y	F _z	ΣF	M _x	M _y	M _z	ΣM
50-32-200	380	350	440	680	460	320	370	670
65-40-200	380	350	440	680	460	320	370	670
65-50-160	530	470	580	910	490	350	400	720
80-65-160	650	600	740	1100	530	380	420	770

Tab. 16 Forces and torques on the pressure flange

9.3.7 Screw specification for the flanges

M12 or M16

9.3.8 Minimum volume flow

Size NEOChem ...	Motor power rating [kW]	Minimum volume flow [l/min] by temperature			
		40 °C	60 °C	80 °C	95 °C
50-32-200	5.5 / 7.5	60	80	100	120
65-40-200	11 / 15 / 18.5	80	100	120	150
65-50-160	5.5 / 7.5	80	100	120	150
80-65-160	11 / 15 / 18.5	100	120	150	180

Tab. 17 Minimum volume flow

9.3.9 Cleaning agents

- Weakly alkaline soap solution
- Steam jet (only for individual parts)

9.4 Maintenance schedule

i The manufacture recommends shorter maintenance intervals if the medium being conveyed contains solid matter. The operating company should choose the maintenance intervals appropriate to the medium being conveyed.

Interval	Designation	Action
Daily	Conveyed fluid	<ul style="list-style-type: none"> ▶ Check temperature. ▶ Check discharge pressure.
	Tank	<ul style="list-style-type: none"> ▶ Check the fill level.
Weekly	Operating temperatures	<ul style="list-style-type: none"> ▶ Check motor temperature.
	Pump	<ul style="list-style-type: none"> ▶ Check the pump for leaks and vibration.
Quarterly	Housing	<ul style="list-style-type: none"> ▶ Check the housing for dirt and damage: <ul style="list-style-type: none"> – Replace the housing if damaged. – Clean the housing if dirty. – Consult the manufacturer in the event of deformed shaft bearings and scratches.
	O-ring and seal	<ul style="list-style-type: none"> ▶ Check the O-ring and seal for damage and replace them if necessary (→ 7.3.2 Disassembling and checking the pump, Page 21). Consult the manufacturer for corroded and swollen parts.
	Impeller	<ul style="list-style-type: none"> ▶ Check the impeller for dirt and damage (→ 7.3.2 Disassembling and checking the pump, Page 21): <ul style="list-style-type: none"> – If the impeller is dirty, clean it. – If the impeller is damaged, replace it. – Consult the manufacturer in the event of the following types of damage: Deformations, cracks or scratches.
	Plain bearing	<ul style="list-style-type: none"> ▶ Check plain bearings for wear (→ 7.3.2 Disassembling and checking the pump, Page 21): <ul style="list-style-type: none"> – Replace worn parts (→ 9.3.5 Wear limits, Page 36). – Consult the manufacturer in the event of damage.
	Shaft and bearing ring	<ul style="list-style-type: none"> ▶ Check the shaft and bearing ring for damage (→ 7.3.2 Disassembling and checking the pump, Page 21): <ul style="list-style-type: none"> – Replace damaged or worn parts (→ 9.3.5 Wear limits, Page 36). – Consult the manufacturer in the event of scratches.
	Undoable screwed connections	<ul style="list-style-type: none"> ▶ Check all connecting screws and tighten them to the specified torque (→ 9.3.4 Tightening torques, Page 35).
As required	Motor	<ul style="list-style-type: none"> ▶ Check the motor against the supplier's documentation and perform maintenance if necessary (→ 1.2 Other applicable documents, Page 5).

Tab. 18 Maintenance schedule

9.5 Declaration of conformity

EU Declaration of Conformity



Manufacturer **SCHMITT-Kreiselpumpen GmbH & Co. KG**
Einsteinstrasse 33
D-76275 Ettlingen

Type of pump **Centrifugal pump**

Pump type **NEOChem Base**

We declare that the design of the listed pumps satisfies the provisions of the EU Directives.
The relevant points satisfy the requirements of the

EC Machinery Directive	2006 / 42 / EC
Low Voltage Directive	2014 / 35 / EU
Electromagnetic Compatibility	2014 / 30 / EU
Harmonized standards applied	EN ISO 12100:2010 EN 809:1998+A1:2009+AC:2010 ISO 15783:2002+A1:2008

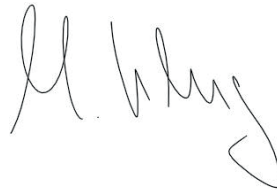

Ettlingen, März 2025, **Moritz Klug**
Einsteinstrasse 33, 76275 Ettlingen
Managing Director / Documentation Officer
SCHMITT-Kreiselpumpen GmbH & Co. KG