

Reinventing
flow.
Since 1964

MPN

Normal-Priming Centrifugal Pumps
Made of PVDF or PP with Magnetic Coupling



MPN

Normal-Priming Centrifugal Pumps
Made of PVDF or PP with Magnetic Coupling

Normal-Priming Centrifugal Pumps

Made of PVDF or PP with Magnetic Coupling

Housing and impeller materials PVDF, PP

Elastomers EPDM, FKM (e.g. Viton®), FEP, FFKM (e.g. Kalrez®)

Bearing material pairings SiC / SiC, PTFE-GF / Al₂O₃ ceramic

The MPN series is one of the most established thermoplastic magnetic drive pump ranges in the industry. Continuously refined over decades of operation, more than 10,000 MPN pumps are in service worldwide. The MPN series features a contact-free, abrasion-free magnetic drive system, eliminating the need for a mechanical seal.

Performance Overview

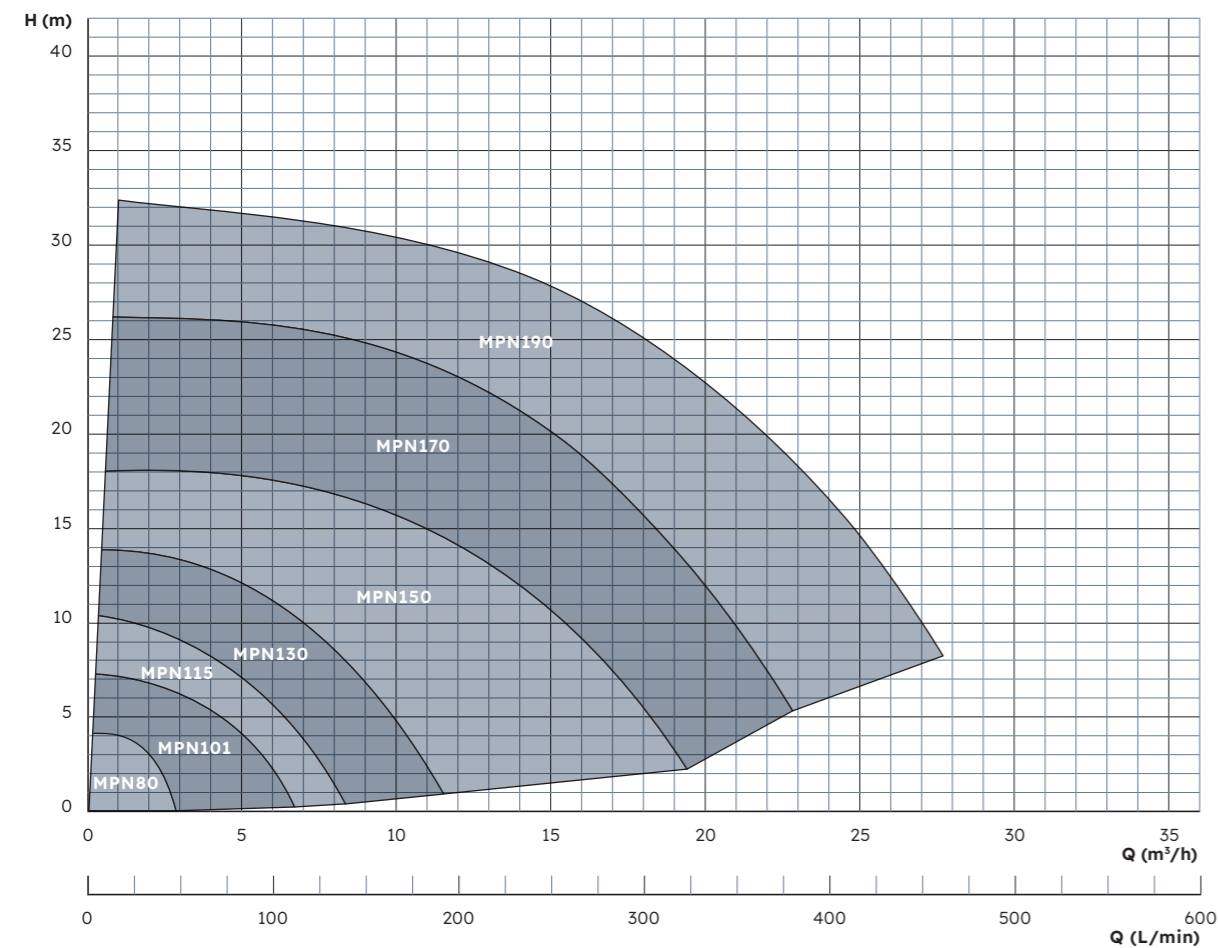

Advantages

- + Hermetically sealed design, eliminating the need for a mechanical seal
- + Particularly suitable for toxic, environmentally hazardous, and corrosive media
- + Capable of intermittent dry running thanks to large-diameter plain bearings

The pump can handle solids up to 3 mm in size and concentrations of up to 10 % by volume. Maximum viscosity: 150 mPa·s. Maximum permissible temperature: 95 °C.

All sizes are also available in ATEX-certified versions (MPN-EX) for ATEX Zones 1 and 2.

Built to Run

More than 10,000 MPN pumps are in operation worldwide – and keep running.

Proven. Preferred. Better.

For 50 years, the MPN has stood for reliability and efficiency. For 50 years, we have continuously refined and improved it.



Description

Characteristics	Chemical-resistant, single-stage, magnetic drive centrifugal pump
Features	<ul style="list-style-type: none"> • Hermetically sealed and absolutely leak-free (no mechanical seal) • Powerful magnetic drive with neodymium magnets • Practically maintenance-free in normal operation due to extra-large slide bearings • Runs in partial dry run conditions due to large diameter PTFE slide bearings – design without impeller shaft • All wetted parts made of high-quality, corrosion-resistant plastics (PVDF or PP) • Threaded connections (ISO 228-1) as standard • Optionally available with flanges (from size 130) • Universally applicable, low-noise and compact close-coupled design • Approved for use in explosive atmospheres Atex zones 1 and 2 • Optionally available with housing parts made of conductive plastic with approval for Atex zone 1 • Corrosion-resistant paint finish • All stainless steel screws in 1.4571 (316Ti) • FDA-certified materials (PVDF versions)
Fields of application	<p>Delivery of acids, bases, lye or other corrosive, harmful or toxic liquids in such applications, where even small leakages are not acceptable and a hermetically sealed pump is required.</p> <p>Delivery of highly pure and sensitive liquids, where contamination must absolutely be avoided.</p> <p>For example in the following applications:</p> <ul style="list-style-type: none"> • Plating and surface coating • Semiconductor technology and solar cell production • PCB and electronics manufacturing • Wastewater and fresh water treatment • Laboratory equipment and medical technology, • Emission controls and gas scrubbers • Battery production and energy storage • High-purity applications, demineralized water, ultrapure water

Characteristics

Available materials	<ul style="list-style-type: none"> • Pump housing / wet end: PVDF, PP • Elastomers: FKM, EPDM, FEP, FFKM • Bearing material pairings: SiC / SiC, PTFE-GF / Al₂O₃ ceramic
Standard motors (available from stock)	<ul style="list-style-type: none"> • Three-phase motors: Δ230/Y400 V, 3-ph @ 50 Hz; Y460 V, 3-ph @ 60 Hz; IP55, Class F, with PTC as standard • All three-phase motors from 0.75 kW comply with energy efficiency class IE3 • Single-phase motors: up to 1.1 kW: 230 V, 1-ph, 50/60 Hz, IP55, Class F • ATEX-certified motors (temperature rating T3)
Special motors (on request)	<ul style="list-style-type: none"> • Special voltages and frequencies • Three-phase motors with integrated frequency converter • ATEX-certified motors with flameproof enclosure and temperature rating T4 • Four-pole motors with 1450 rpm @ 50 Hz / 1650 rpm @ 60 Hz • UL- and CSA-certified motors • Special types of protection, e.g., IP65 • Special insulation classes, e.g., tropical insulation • Multi-voltage, e.g., Δ220–290/Y380–500 V @ 50 Hz; Δ220–332/Y380–575 V @ 60 Hz • Direct-current motors (DC or BLDC)
Operating conditions	<ul style="list-style-type: none"> • Flow rate up to 42 m³/h • Maximum head up to 27 m • Liquid temperature: -5°C to 95°C (PVDF); 0°C to 80°C (PP) • Ambient temperature: -10°C to 40°C, higher temperatures on request • Can be adapted to high-density liquids (up to 2.0)

Performance Curves **MPN 80** (0.18 kW) / **MPN 101** (0.18 kW)

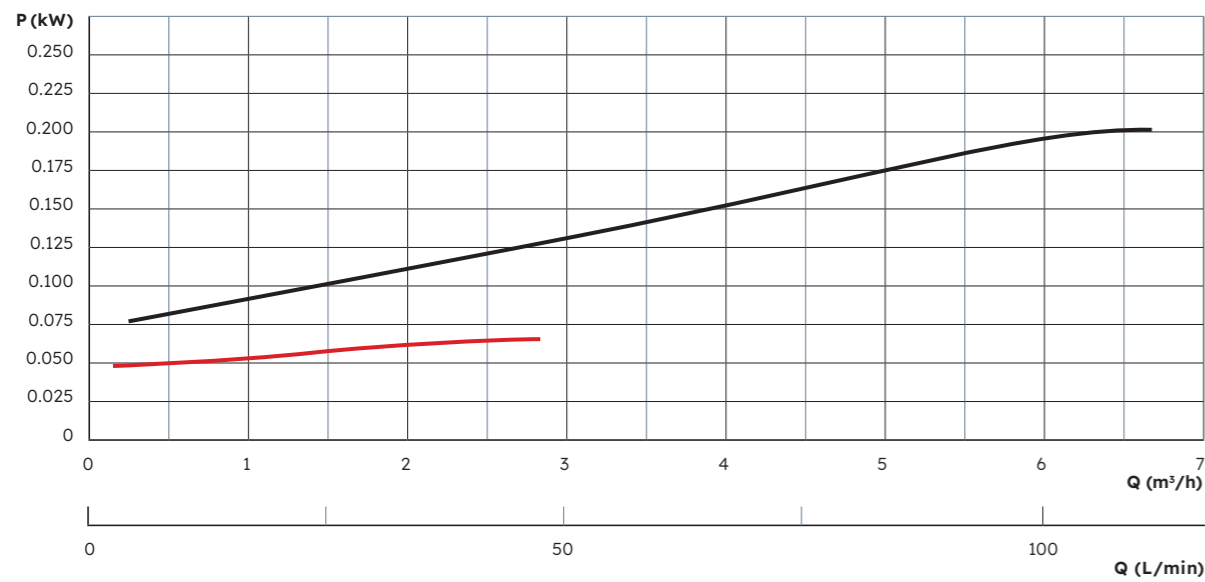
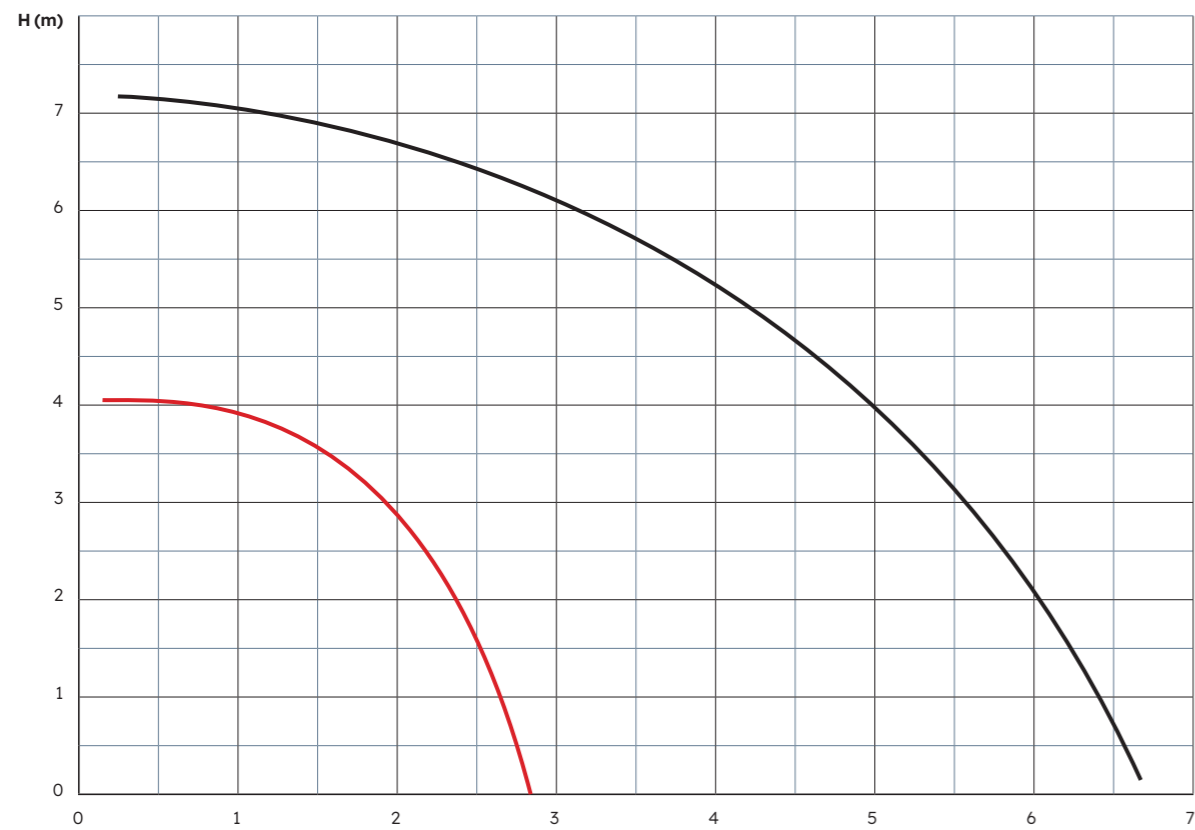

Performance Curves **MPN 115** (0.25 kW) / **MPN 130** (0.55 kW)

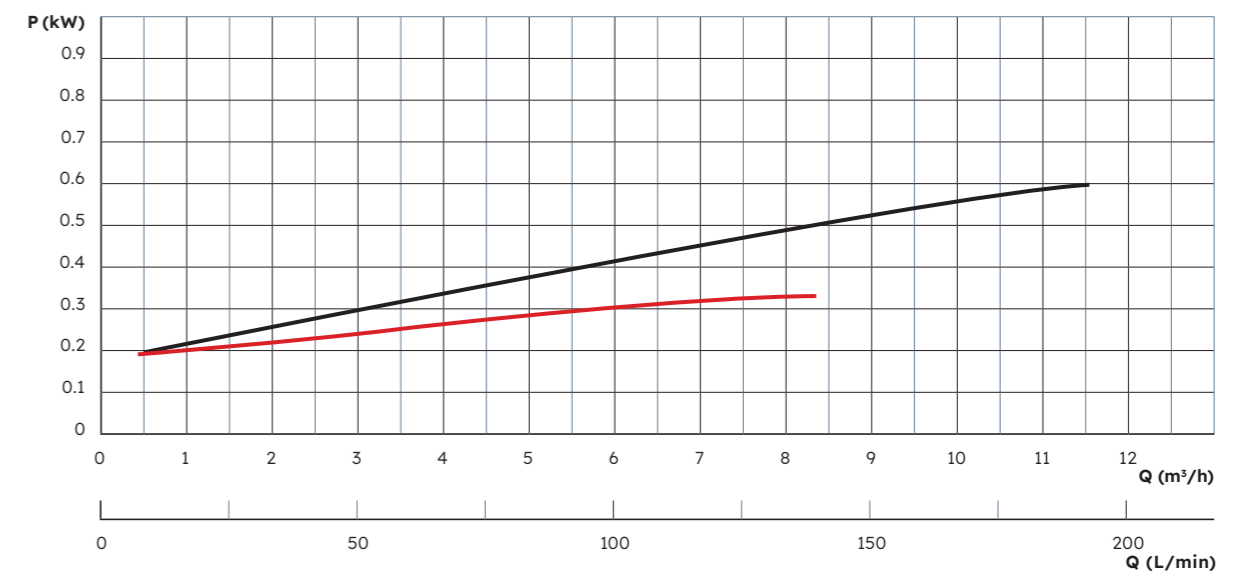

Performance Curves **MPN 150** (1.1kW) / **MPN 170**

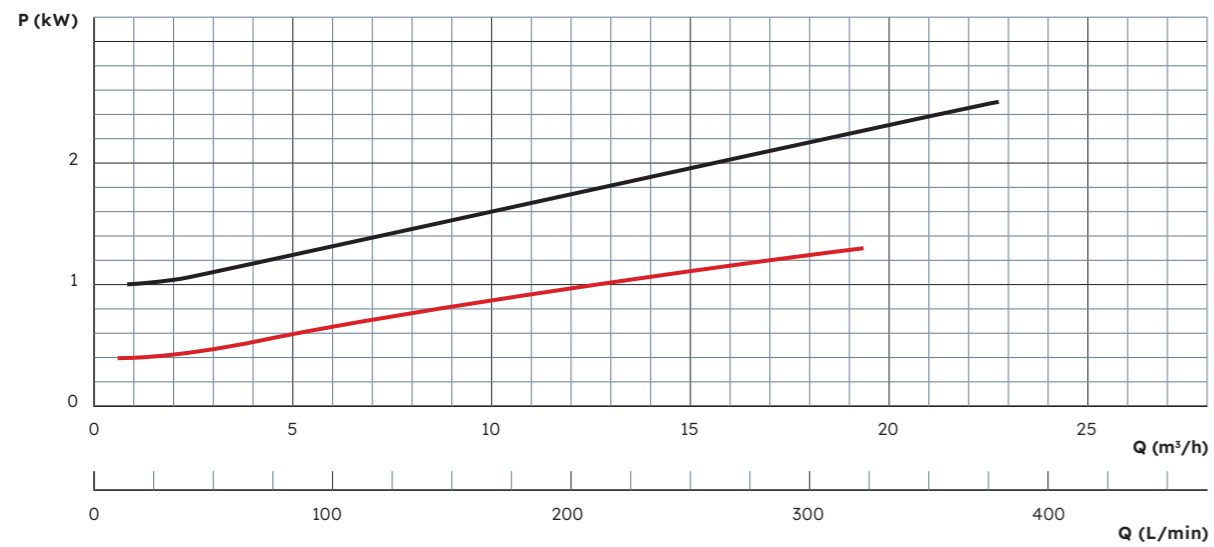
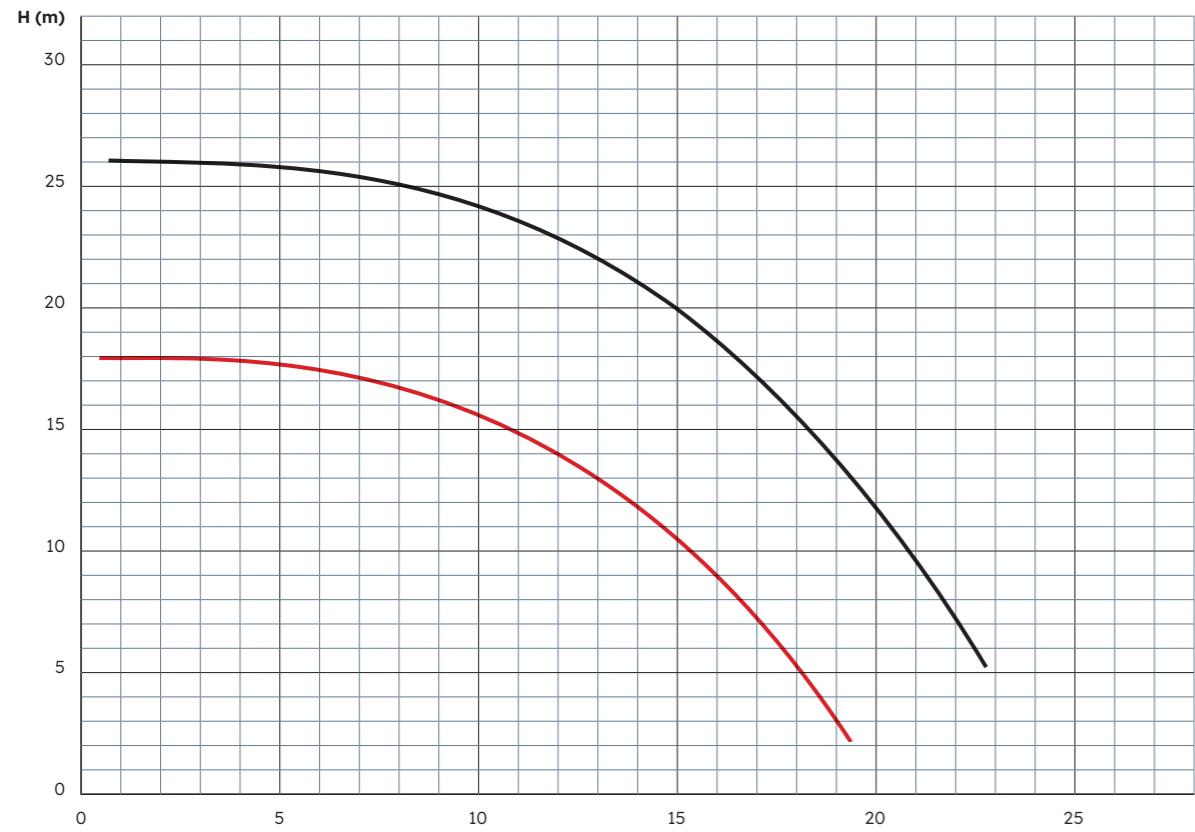

Performance Curve **MPN 190** (3.0 kW oder 4.0 kW)

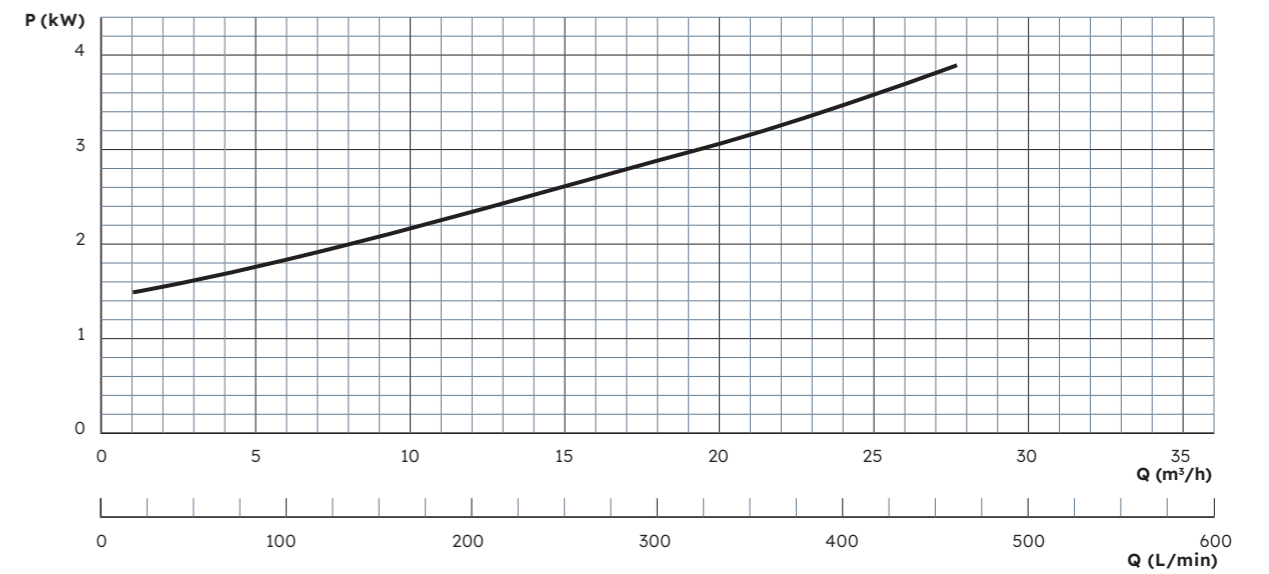

Dimensions

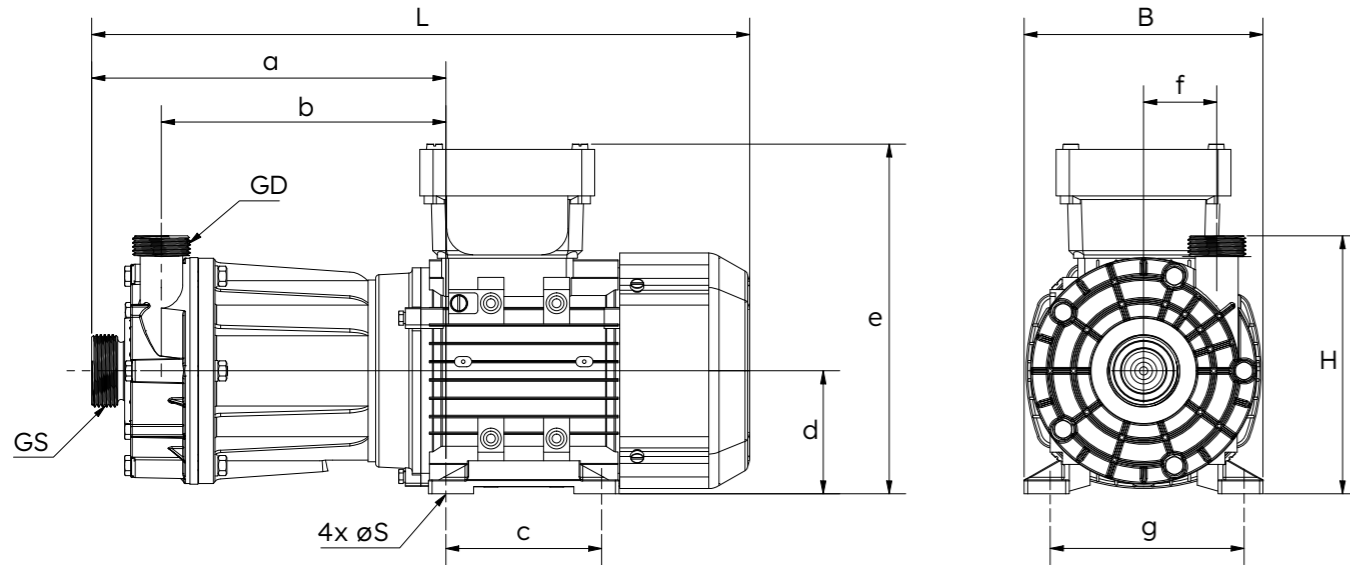

Type	GS		GD		L (mm)	B (mm)	H (mm)	S (mm)	a (mm)	b (mm)	c (mm)	d (mm)	e (mm)	f (mm)	g (mm)	Weight (kg)
	Thread	DN	Thread	DN												
80	G ³ / ₄ "	10	G ³ / ₄ "	10	317	123	115	7	163	128	80	63	168	25	100	4
101	G1"	15	G1"	15	322	123	125	7	165	130	80	63	168	31	100	4
115	G1"	15	G1"	15	354	123	134	7	184	147	80	63	186	37	100	5
130	G1 ¹ / ₄ "	20	G1"	15	380	138	149	7	205	165	90	71	202	42	112	8
150	G1 ¹ / ₂ "	25	G1 ¹ / ₄ "	20	441	157	171	10	230	182	100	80	220	47	125	18
170	G2"	32	G1 ¹ / ₂ "	25	517	173	245	10	278	225	125	90	191	59	140	28
190	G2"	32	G1 ¹ / ₂ "	25	547	196	211	12	295	237	140	100	259	66	160	38

All dimensions are provided for reference purposes only and are subject to change without notice. Dimensional variations may occur depending on motor type, manufacturer, or configuration. A certified dimensional drawing will be supplied with the official quotation or order confirmation.

Fittings

A comprehensive range of accessories is available for all Schmitt pumps, facilitating seamless integration into your system:

- + Flange adapters
- + Hose connectors
- + Weld-on fittings for stainless steel piping
- + Reducers and expanders
- + NPT-threaded adaptors
- + Inlet strainers for vertical pumps
- + Extension pipes for vertical pumps

Spare Parts

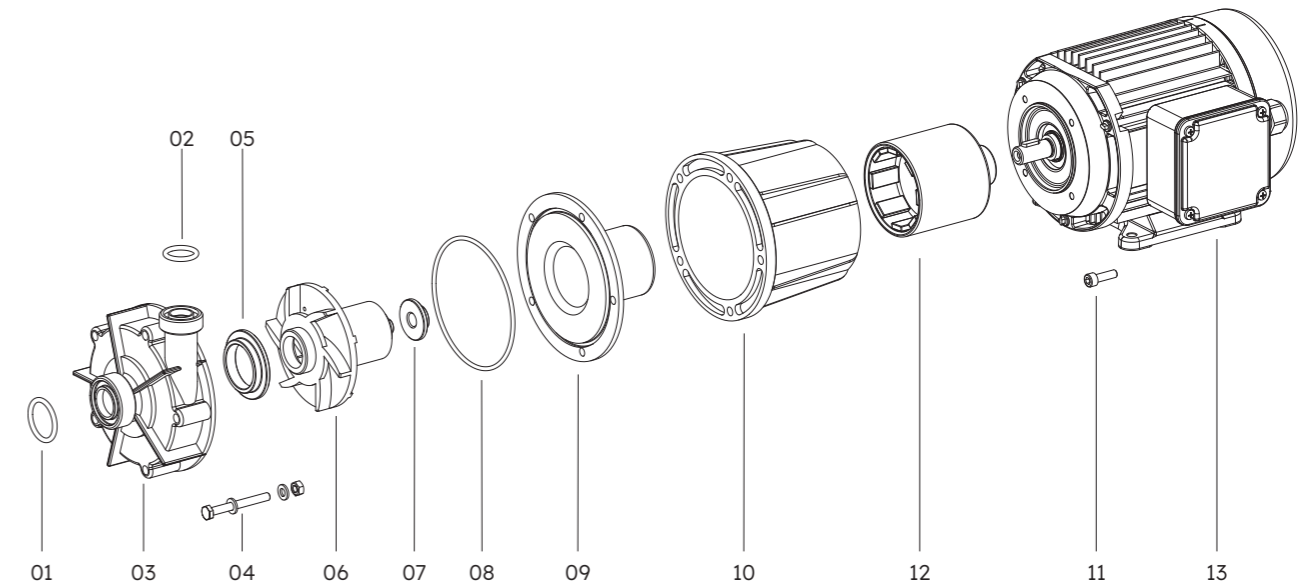

Position	Description	Available materials
01	O-ring (inlet port)	FKM, EPDM, FEP, FFKM
02	O-ring (outlet port)	FKM, EPDM, FEP, FFKM
03	Pump housing incl. slide bearing ring	Housing: PVDF, PP Ring: Ceramics Al ₂ O ₃ , SiC
04	Hexagon bolt, washer, nut	V4A (1.4571)
05	Front bearing	PTFE, SiC
06	Impeller	PVDF, PP
07	Back bearing	PTFE, SiC
08	Housing seal	FKM, EPDM, FEP, FFKM
09	Backplate incl. slide bearing ring	Housing: PVDF, PP Ring: Ceramics Al ₂ O ₃ , SiC
10	Flange	PP, aluminium
11	Cylinder bolt	V4A (1.4571)
12	Drive magnet	
13	Motor	

SCHMITT

Reinventing flow. Since 1964

NHM

Normal-Priming Centrifugal Pumps
Made of PVDF or PP with Magnetic Coupling



SCHMITT

Reinventing flow. Since 1964

MPN

Normal-Priming Centrifugal Pumps
Made of PVDF or PP with Magnetic Coupling



SCHMITT

Reinventing flow. Since 1964

U

Normal-Priming Centrifugal Pumps
Made of PVDF or PP with Single Mechanical Seal



SCHMITT

T

Sealless Vertical Centrifugal Pumps
Made of PVDF or PP Dry-Run Safe



Reinventing flow. Since 1964

SCHMITT

UP | UP-DO

Normal-Priming Centrifugal Pumps
Made of Stainless Steel with Single or Double Mechanical Seal

Reinventing flow. Since 1964



SCHMITT

Reinventing flow. Since 1964

SMP

Self-Priming Centrifugal Pumps
Made of PP with Magnetic Coupling



SCHMITT

Reinventing flow. Since 1964

P

Normal-Priming Turbine Pumps
Made of PVDF or PP with Magnetic Coupling



SCHMITT

NEOCHEM BASE

Standardized Chemical Pumps
ETFE-lined with Magnetic Coupling



Reinventing flow. Since 1964

SCHMITT

NEOCHEM CORE

Heavy-Duty Standardized Chemical Pumps
FFA-lined with Magnetic Coupling



Reinventing flow. Since 1964

SCHMITT-Kreiselpumpen GmbH & Co. KG
Einsteinstrasse 33
76275 Ettlingen, Germany
T +49 7243 5453-0
F +49 7243 5453-22
sales@schmitt-pumpen.de
schmitt-pumpen.de