

Chemical Resistance

Reference for the chemical compatibility
of our pump materials with various media



Reinventing
flow.

flow. **Reinventing**
flow.

Chemical Resistance

Chemical-resistant pumps for aggressive and hazardous media

Notes on the Chemical Resistance Chart

The following chemical resistance chart is intended as a guide for selecting suitable materials for use with various pumped media in Schmitt centrifugal pumps. The information provided is based on generally available material data as well as practical experience. Typical influencing factors such as concentration, temperature and the chemical properties of the medium have been taken into account.

Due to the wide variety of possible operating conditions, the ratings given should be regarded as non-binding guideline values only. Interactions between the medium and the material, as well as temperature, pressure, impurities and specific operating conditions, may significantly influence the actual behavior in service.

Therefore, no binding statement regarding the suitability of a material for a specific application can be derived from this chart. The operator is responsible for verifying the compatibility of the materials under the actual operating conditions and, where necessary, carrying out appropriate tests. No warranty or liability claims can be derived from the information provided in this chart.

We will be pleased to assist you in selecting suitable materials for your application. For individual advice or special operating conditions, please contact our technical sales team at any time.

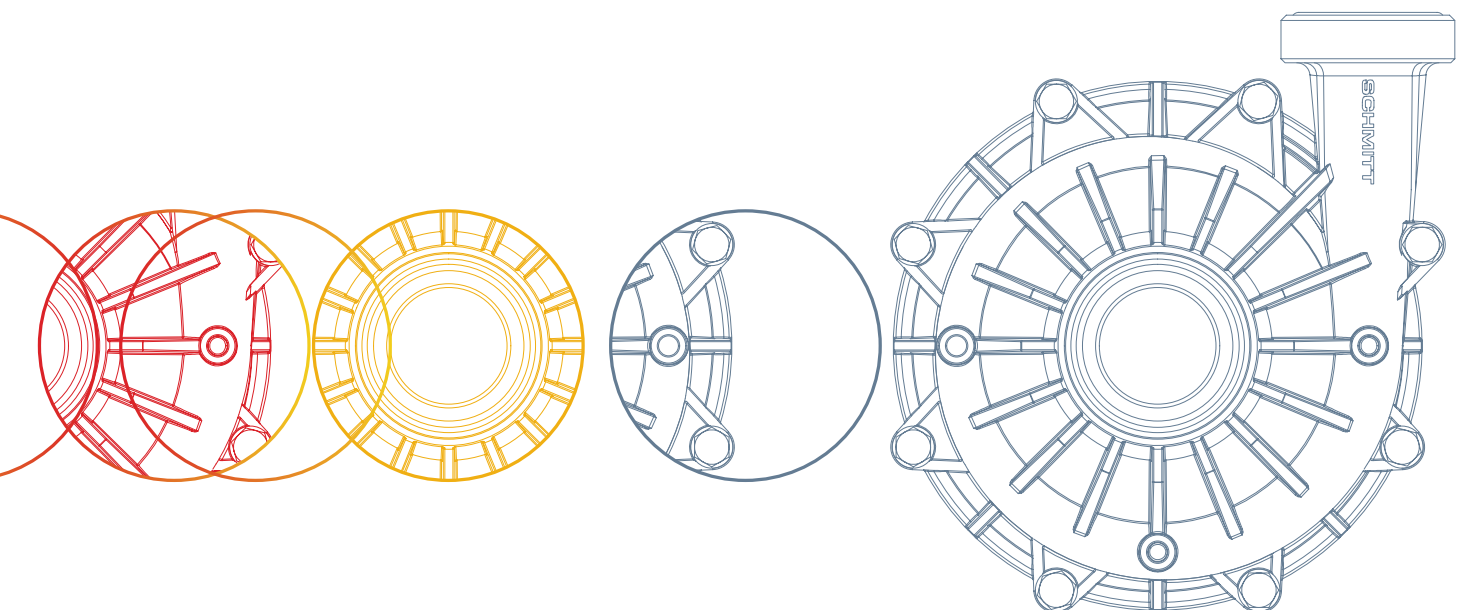

A

Description/formula		Temperature °C	PP	PVDF	Stainless steel 1.4571	Hastelloy C4 2.4610	FKM	EPDM	PTFE/FEP	FFKM	Density kg/dm³
Acetaldehyde 40%	CH ₃ -CHO	20	●	●	●	●	●	●	●	●	
		40	●	●	●	●	●	●	●	●	
		60	●	●	●	●	●	●	●	●	
Acetaldehyde TP	CH ₃ -CHO	20	●	●	●	●	●	●	●	●	0.79
		40	●	●	●	●	●	●	●	●	
Acetamide TP	CH ₃ -CO-NH ₂	20	●	●	●	●	●	●	●	●	0.98
		40	●	●	●	●	●	●	●	●	
		60	●	●	●	●	●	●	●	●	
Acetic acid 10%	CH ₃ COOH	20	●	●	●	●	●	●	●	●	
		40	●	●	●	●	●	●	●	●	
		60	●	●	●	●	●	●	●	●	
Acetic acid 25%	CH ₃ COOH	20	●	●	●	●	●	●	●	●	
		40	●	●	●	●	●	●	●	●	
		60	●	●	●	●	●	●	●	●	
Acetic acid 50%	CH ₃ COOH	20	●	●	●	●	●	●	●	●	
		40	●	●	●	●	●	●	●	●	
		60	●	●	●	●	●	●	●	●	
Acetic acid 80%	CH ₃ COOH	20	●	●	●	●	●	●	●	●	
		40	●	●	●	●	●	●	●	●	
		60	●	●	●	●	●	●	●	●	
Acetic acid 100%	CH ₃ COOH	20	●	●	●	●	●	●	●	●	1.05
		40	●	●	●	●	●	●	●	●	
		60	●	●	●	●	●	●	●	●	
Acetic acid butylester TP	C ₆ H ₁₂ O ₂	20	●	●	●	●	●	●	●	0.88	
Acetic anhydride TP	(CH ₃ CO) ₂ O	20	●	●	●	●	●	●	●	●	1.09
		40	●	●	●	●	●	●	●	●	
		60	●	●	●	●	●	●	●	●	
Acetone 10%	CH ₃ -CO-CH ₃ +H ₂ O	20	●	●	●	●	●	●	●	●	
		40	●	●	●	●	●	●	●	●	
		60	●	●	●	●	●	●	●	●	
Acetone TP	CH ₃ -CO-CH ₃	20	●	●	●	●	●	●	●	●	0.79
		40	●	●	●	●	●	●	●	●	
		60	●	●	●	●	●	●	●	●	
Acetonitrile TP	CH ₃ -CN	20	●	●	●	●	●	●	●	●	0.78
		40	●	●	●	●	●	●	●	●	
		60	●	●	●	●	●	●	●	●	
Acetylene dichloride TP	C ₂ H ₂ Cl ₂	20	●	●	●	●	●	●	●	●	1.22
		40	●	●	●	●	●	●	●	●	
		60	●	●	●	●	●	●	●	●	
Acrylic acid butylester TP	C ₉ H ₈ O ₂	20	●	●	●	●	●	●	●		
Acrylonitrile TP	CH ₂ =CH-CN	20	●	●	●	●	●	●	●	●	0.81
		40	●	●	●	●	●	●	●	●	
		60	●	●	●	●	●	●	●	●	

C = commercial composition, SS = saturated solution, TP = technically pure; ● = resistant, ● = conditionally resistant, ● = not resistant

Description/formula		Temperature °C	PP	PVDF	Stainless steel 1.4571	Hastelloy C4 2.4610	FKM	EPDM	PTFE/FEP	FFKM	Density kg/dm ³
Adipic acid SS	C ₇ H ₁₂ O ₂	20	●	●	●	●	●	●	●	●	0.89
		40	●	●	●	●	●	●	●	●	
		60	●	●	●	●	●	●	●	●	
Allyl alcohol 96%	H ₂ C=CH-CH ₂ -OH	20	●	●	●	●	●	●	●	●	0.87
		40	●	●	●	●	●	●	●	●	
		60	●	●	●	●	●	●	●	●	
Alum 50%	KAl(SO ₄) ₂ ·H ₂ O	20	●	●	●	●	●	●	●	●	
		40	●	●	●	●	●	●	●	●	
		60	●	●	●	●	●	●	●	●	
Aluminium chloride 10%	AlCl ₃	20	●	●	●	●	●	●	●	●	
		40	●	●	●	●	●	●	●	●	
		60	●	●	●	●	●	●	●	●	
Aluminium chloride SS	AlCl ₃	20	●	●	●	●	●	●	●	●	2.40
		40	●	●	●	●	●	●	●	●	
		60	●	●	●	●	●	●	●	●	
Aluminium nitrate SS	Al(NO ₃) ₃	20	●	●	●	●	●	●	●	●	
		40	●	●	●	●	●	●	●	●	
		60	●	●	●	●	●	●	●	●	
Aluminium sulphate 10%	Al ₂ (SO ₄) ₃	20	●	●	●	●	●	●	●	●	
		40	●	●	●	●	●	●	●	●	
		60	●	●	●	●	●	●	●	●	
Aluminium sulphate SS	Al ₂ (SO ₄) ₃	20	●	●	●	●	●	●	●	●	1.61
		40	●	●	●	●	●	●	●	●	
		60	●	●	●	●	●	●	●	●	
Ammonia water SS	NH ₄ OH	20	●	●	●	●	●	●	●	●	
		40	●	●	●	●	●	●	●	●	
		60	●	●	●	●	●	●	●	●	
Ammonium acetate	CH ₃ -COONH ₄ +H ₂ O	20	●	●	●	●	●	●	●	●	
		40	●	●	●	●	●	●	●	●	
		60	●	●	●	●	●	●	●	●	
Ammonium bicarbonate 25%	(NH ₄) ₂ CO ₃ +H ₂ O	20	●	●	●	●	●	●	●	●	
		40	●	●	●	●	●	●	●	●	
		60	●	●	●	●	●	●	●	●	
Ammonium bromide 40%	NH ₄ Br+H ₂ O	20	●	●	●	●	●	●	●	●	1.27
		40	●	●	●	●	●	●	●	●	
		60	●	●	●	●	●	●	●	●	
Ammonium carbonate 25%	(NH ₄) ₂ CO ₃ +H ₂ O	20	●	●	●	●	●	●	●	●	
		40	●	●	●	●	●	●	●	●	
		60	●	●	●	●	●	●	●	●	
Ammonium chloride SS	NH ₄ Cl+H ₂ O	20	●	●	●	●	●	●	●	●	1.07
		40	●	●	●	●	●	●	●	●	
		60	●	●	●	●	●	●	●	●	
Ammonium dihydrogen phosphate 10%	NH ₄ H ₂ PO ₄ +H ₂ O	20	●	●	●	●	●	●	●		

C = commercial composition, SS = saturated solution, TP = technically pure; ● = resistant, ● = conditionally resistant, ● = not resistant

Description/formula		Temperature °C	PP	PVDF	Stainless steel 1.4571	Hastelloy C4 2.4610	FKM	EPDM	PTFE/FEP	FFKM	Density kg/dm³
Ammonium dihydrogen phosphate 10%	NH ₄ H ₂ PO ₄ +H ₂ O	40	●	●	●	●	●	●	●	●	
		60	●	●	●	●	●	●	●	●	
Ammonium fluoride 14%	NH ₄ F+H ₂ O	20	●	●	●	●	●	●	●	●	
		40	●	●	●	●	●	●	●	●	
		60	●	●	●	●	●	●	●	●	
Ammonium fluorosilicate TP	(NH ₄) ₂ SiF ₆ +H ₂ O	20	●	●	●	●	●	●	●	●	
Ammonium hydrogen fluoride 50%	(NH ₄)HF ₂	20	●	●	●	●	●	●	●	●	
		40	●	●	●	●	●	●	●	●	
		60	●	●	●	●	●	●	●	●	
Ammonium nitrate 10%	NH ₄ NO ₃ +H ₂ O	20	●	●	●	●	●	●	●	●	
		40	●	●	●	●	●	●	●	●	
		60	●	●	●	●	●	●	●	●	
Ammonium nitrate 50%	NH ₄ NO ₃ +H ₂ O	20	●	●	●	●	●	●	●	●	1.23
		40	●	●	●	●	●	●	●	●	
		60	●	●	●	●	●	●	●	●	
Ammonium nitrate SS	NH ₄ NO ₃ +H ₂ O	20	●	●	●	●	●	●	●	●	
		40	●	●	●	●	●	●	●	●	
		60	●	●	●	●	●	●	●	●	
Ammonium oxalate TP	(COONH ₄) ₂ + H ₂ O	20	●	●	●	●	●	●	●	●	1.50
		40	●	●	●	●	●	●	●	●	
		60	●	●	●	●	●	●	●	●	
Ammonium perchlorate 14%	NH ₄ ClO ₄ +H ₂ O	20	●	●	●	●	●	●	●	●	1.07
		40	●	●	●	●	●	●	●	●	
		60	●	●	●	●	●	●	●	●	
Ammonium phosphate 10%	NH ₄ H ₂ PO ₄ +H ₂ O	20	●	●	●	●	●	●	●	●	
		40	●	●	●	●	●	●	●	●	
		60	●	●	●	●	●	●	●	●	
Ammonium sulphate 10%	(NH ₄) ₂ SO ₄ +H ₂ O	20	●	●	●	●	●	●	●	●	
		40	●	●	●	●	●	●	●	●	
		60	●	●	●	●	●	●	●	●	
Ammonium sulphate 50%	(NH ₄) ₂ SO ₄ +H ₂ O	20	●	●	●	●	●	●	●	●	1.28
		40	●	●	●	●	●	●	●	●	
		60	●	●	●	●	●	●	●	●	
Ammonium sulphate SS	(NH ₄) ₂ SO ₄ +H ₂ O	20	●	●	●	●	●	●	●	●	1.30
		40	●	●	●	●	●	●	●	●	
		60	●	●	●	●	●	●	●	●	
Ammonium sulphide 10%	NH ₄ S+H ₂ O	20	●	●	●	●	●	●	●	●	
		40	●	●	●	●	●	●	●	●	
		60	●	●	●	●	●	●	●	●	
Amyl acetate TP	CH ₃ -COOC ₅ H ₁₁	20	●	●	●	●	●	●	●	●	0.88
		40	●	●	●	●	●	●	●	●	
		60	●	●	●	●	●	●	●	●	
Amyl alcohol TP	C ₅ H ₁₁ OH	20	●	●	●	●	●	●	●	0.82	

C = commercial composition, SS = saturated solution, TP = technically pure; ● = resistant, ● = conditionally resistant, ● = not resistant

Description/formula		Temperature °C	PP	PVDF	Stainless steel 1.4571	Hastelloy C4 2.4610	FKM	EPDM	PTFE/FEP	FFKM	Density kg/dm ³
Amyl alcohol TP	C ₅ H ₁₁ OH	40	●	●	●	●	●	●	●	●	
		60	●	●	●	●	●	●	●	●	
Amyl chloride TP	CH ₃ (CH ₂) ₄ Cl	20	●	●	●	●	●	●	●	●	0.87
		40	●	●	●	●	●	●	●	●	
		60	●	●	●	●	●	●	●	●	
Aniline TP	C ₆ H ₅ NH ₂	20	●	●	●	●	●	●	●	●	1.01
		40	●	●	●	●	●	●	●	●	
		60	●	●	●	●	●	●	●	●	
Anon TP	C ₆ H ₁₀ O	20	●	●	●	●	●	●	●	0.95	
Aqua regia	3HCl+HNO ₃	20	●	●	●	●	●	●	●	●	
		40	●	●	●	●	●	●	●	●	
		60	●	●	●	●	●	●	●	●	
Arsenic acid 10%	H ₃ ASO ₄	20	●	●	●	●	●	●	●	●	
		40	●	●	●	●	●	●	●	●	
		60	●	●	●	●	●	●	●	●	
Arsenic acid 80%	H ₃ ASO ₄	20	●	●	●	●	●	●	●	●	
		40	●	●	●	●	●	●	●	●	
		60	●	●	●	●	●	●	●	●	
Barium chloride 10%	BaCl ₂	20	●	●	●	●	●	●	●	●	
		40	●	●	●	●	●	●	●	●	
Barium chloride 25%	BaCl ₂	20	●	●	●	●	●	●	●	●	1.27
		40	●	●	●	●	●	●	●	●	
Barium hydroxide SS	Ba(OH) ₂	20	●	●	●	●	●	●	●	●	
		40	●	●	●	●	●	●	●	●	
		60	●	●	●	●	●	●	●	●	
Barium sulphide 10%	BaS	20	●	●	●	●	●	●	●	●	
Battery acid 40%	H ₂ SO ₄	20	●	●	●	●	●	●	●	●	
		40	●	●	●	●	●	●	●	●	
		60	●	●	●	●	●	●	●	●	
Benzaldehyde	C ₆ H ₅ CHO	20	●	●	●	●	●	●	●	●	1.05
		40	●	●	●	●	●	●	●	●	
		60	●	●	●	●	●	●	●	●	
Benzaldehyde 30%	C ₆ H ₅ CHO	20	●	●	●	●	●	●	●		
Benzaldehyde TP	C ₆ H ₅ CHO	20	●	●	●	●	●	●	●	1.05	
Benzene TP	C ₆ H ₆	20	●	●	●	●	●	●	●	0.88	
Benzoic acid 10%	C ₆ H ₅ COOH	20	●	●	●	●	●	●	●	●	1.27
		40	●	●	●	●	●	●	●	●	
		60	●	●	●	●	●	●	●	●	
Benzyl alcohol TP	C ₆ H ₅ -CH ₂ OH	20	●	●	●	●	●	●	●	●	1.04
		40	●	●	●	●	●	●	●	●	
		60	●	●	●	●	●	●	●	●	
Benzyl chloride	C ₆ H ₅ -CH ₂ Cl	20	●	●	●	●	●	●	●	●	1.11
		40	●	●	●	●	●	●	●	●	

B

C = commercial composition, SS = saturated solution, TP = technically pure; ● = resistant, ● = conditionally resistant, ● = not resistant

Description/formula		Temperature °C	PP	PVDF	Stainless steel 1.4571	Hastelloy C4 2.4610	FKM	EPDM	PTFE/FEP	FFKM	Density kg/dm³
Benzyl chloride	C ₆ H ₅ -CH ₂ Cl	60	●	●	●	●	●	●	●	●	
Bitter almond oil	C ₆ H ₅ CHO	20	●	●	●	●	●	●	●	●	1.05
		40	●	●	●	●	●	●	●	●	
		60	●	●	●	●	●	●	●	●	
Bitter almond oil 30%	C ₆ H ₅ CHO	20	●	●	●	●	●	●	●		
Bitter almond oil TP	C ₆ H ₅ CHO	20	●	●	●	●	●	●	●	1.05	
Borax 10%	Na ₂ B ₄ O ₇ +10 H ₂ O	20	●	●	●	●	●	●	●	●	1.03
		40	●	●	●	●	●	●	●	●	
		60	●	●	●	●	●	●	●	●	
Borax SS	Na ₂ B ₄ O ₇ +10 H ₂ O	20	●	●	●	●	●	●	●	●	
		40	●	●	●	●	●	●	●	●	
		60	●	●	●	●	●	●	●	●	
Boric acid 10%	H ₃ BO ₃ +H ₂ O	20	●	●	●	●	●	●	●	●	1.01
		40	●	●	●	●	●	●	●	●	
		60	●	●	●	●	●	●	●	●	
Boric acid SS	H ₃ BO ₃ +H ₂ O	20	●	●	●	●	●	●	●	●	
		40	●	●	●	●	●	●	●	●	
		60	●	●	●	●	●	●	●	●	
Boron trifluoride 10%	BF ₃ +H ₂ O	20	●	●	●	●	●	●	●		
Brake fluid	Glycol ether		●	●	●	●	●	●	●		
Bromic acid 10%	HBrO ₃	20	●	●	●	●	●	●	●	●	
		40	●	●	●	●	●	●	●	●	
		60	●	●	●	●	●	●	●	●	
Bromine TP	Br ₂	20	●	●	●	●	●	●	●	3.19	
Butanetriol TP	C ₄ H ₁₀ O ₃	20	●	●	●	●	●	●	●		
Butanol TP	C ₄ H ₉ OH	20	●	●	●	●	●	●	●	●	0.81
		40	●	●	●	●	●	●	●	●	
		60	●	●	●	●	●	●	●	●	
Butanone (MEK) TP	C ₄ H ₈ O	20	●	●	●	●	●	●	●	●	0.81
		40	●	●	●	●	●	●	●	●	
		60	●	●	●	●	●	●	●	●	
Butenal, trans-2 TP	C ₄ H ₆ O	20	●	●	●	●	●	●	●		
Butyl acetate TP	C ₆ H ₁₂ O ₂	20	●	●	●	●	●	●	●	0.88	
Butyl acrylate TP	C ₉ H ₉ O ₂	20	●	●	●	●	●	●	●		
Butyl alcohol TP	C ₄ H ₉ OH	20	●	●	●	●	●	●	●	●	0.81
		40	●	●	●	●	●	●	●	●	
		60	●	●	●	●	●	●	●	●	
Butyl chloride TP	C ₄ H ₉ Cl	20	●	●	●	●	●	●	●	●	0.89
		40	●	●	●	●	●	●	●	●	
		60	●	●	●	●	●	●	●	●	
Butyl ether TP	C ₈ H ₁₈ O	20	●	●	●	●	●	●	●	●	0.77
		40	●	●	●	●	●	●	●	●	
		60	●	●	●	●	●	●	●	●	

C = commercial composition, SS = saturated solution, TP = technically pure; ● = resistant, ● = conditionally resistant, ● = not resistant

Description/formula		Temperature °C	PP	PVDF	Stainless steel 1.4571	Hastelloy C4 2.4610	FKM	EPDM	PTFE/FEP	FFKM	Density kg/dm ³
Butylene glycol 10%	HO(CH ₂) ₄ OH	20	●	●	●	●	●	●	●	●	
		40	●	●	●	●	●	●	●	●	
		60	●	●	●	●	●	●	●	●	
Butylene glycol TP	HO(CH ₂) ₄ OH	20	●	●	●	●	●	●	●	●	
		40	●	●	●	●	●	●	●	●	
		60	●	●	●	●	●	●	●	●	
Butylphen TP	HOC ₆ H ₄ C(CH ₃) ₃	20	●	●	●	●	●	●	●		
Butylphenol TP	HOC ₆ H ₄ C(CH ₃) ₃	20	●	●	●	●	●	●	●		
Butyric acid 20%	C ₃ H ₇ COOH	20	●	●	●	●	●	●	●	0.88	
Butyric acid TP	C ₃ H ₇ COOH	20	●	●	●	●	●	●	●	0.96	
Calcium bisulphite 10%	Ca(HSO ₃) ₂	20	●	●	●	●	●	●	●		
Calcium bisulphite SS	Ca(HSO ₃) ₂	20	●	●	●	●	●	●	●		
		40	●	●	●	●	●	●	●		
		60	●	●	●	●	●	●	●		
Calcium chlorate 10%	CaClO ₃ +H ₂ O	20	●	●	●	●	●	●	●		
Calcium chloride 10%	CaCl ₂ +H ₂ O	20	●	●	●	●	●	●	●		
		40	●	●	●	●	●	●	●		
		60	●	●	●	●	●	●	●		
Calcium chloride SS	CaCl ₂ +H ₂ O	20	●	●	●	●	●	●	●	1.40	
		40	●	●	●	●	●	●	●		
		60	●	●	●	●	●	●	●		
Calcium hydroxide 15%	Ca(OH) ₂	20	●	●	●	●	●	●	●		
		40	●	●	●	●	●	●	●		
		60	●	●	●	●	●	●	●		
Calcium hypochlorite 10%	Ca(OCl) ₂	20	●	●	●	●	●	●	●		
		40	●	●	●	●	●	●	●		
		60	●	●	●	●	●	●	●		
Calcium nitrate 50%	Ca(NO ₃) ₂	20	●	●	●	●	●	●	●	1.48	
		40	●	●	●	●	●	●	●		
Camphor	C ₁₀ H ₁₆ O	20	●	●	●	●	●	●	●		
		40	●	●	●	●	●	●	●		
		60	●	●	●	●	●	●	●		
Caprylic acid	CH ₃ (CH ₂) ₆ COOH	20	●	●	●	●	●	●	●	0.92	
		40	●	●	●	●	●	●	●		
		60	●	●	●	●	●	●	●		
Carbamide 10%	CH ₄ N ₂ O	20	●	●	●	●	●	●	●		
		40	●	●	●	●	●	●	●		
		60	●	●	●	●	●	●	●		
Carbon disulphide TP	CS ₂	20	●	●	●	●	●	●	●	1.27	
		40	●	●	●	●	●	●	●		
		60	●	●	●	●	●	●	●		
Carbon tetrachloride TP	CCl ₄	20	●	●	●	●	●	●	●	1.59	
		40	●	●	●	●	●	●	●		



C = commercial composition, SS = saturated solution, TP = technically pure; ● = resistant, ● = conditionally resistant, ● = not resistant

Description/formula		Temperature °C	PP	PVDF	Stainless steel 1.4571	Hastelloy C4 2.4610	FKM	EPDM	PTFE/FEP	FFKM	Density kg/dm ³
Carbon tetrachloride TP	CCl ₄	60	●	●	●	●	●	●	●	●	
Carboxylic acids 100%	C ₁₇ H ₃₃ CO ₂ H	20	●	●	●	●	●	●	●	●	0.90
		40	●	●	●	●	●	●	●	●	
		60	●	●	●	●	●	●	●	●	
Castor oil C		20	●	●	●	●	●	●	●	●	0.96
		40	●	●	●	●	●	●	●	●	
		60	●	●	●	●	●	●	●	●	
Caustic baryta SS	Ba(OH) ₂	20	●	●	●	●	●	●	●	●	
		40	●	●	●	●	●	●	●	●	
		60	●	●	●	●	●	●	●	●	
Caustic potash 20%	KOH	20	●	●	●	●	●	●	●	●	1.19
		40	●	●	●	●	●	●	●	●	
		60	●	●	●	●	●	●	●	●	
Caustic potash 30%	KOH	20	●	●	●	●	●	●	●	●	1.29
		40	●	●	●	●	●	●	●	●	
		60	●	●	●	●	●	●	●	●	
Caustic potash 60%	KOH	20	●	●	●	●	●	●	●	●	1.63
		40	●	●	●	●	●	●	●	●	
		60	●	●	●	●	●	●	●	●	
Caustic soda 10%	NaOH	20	●	●	●	●	●	●	●	●	1.16
		40	●	●	●	●	●	●	●	●	
		60	●	●	●	●	●	●	●	●	
Caustic soda 30%	NaOH	20	●	●	●	●	●	●	●	●	1.33
		40	●	●	●	●	●	●	●	●	
		60	●	●	●	●	●	●	●	●	
Caustic soda 50%	NaOH	20	●	●	●	●	●	●	●	●	1.53
		40	●	●	●	●	●	●	●	●	
		60	●	●	●	●	●	●	●	●	
Cellosolve TP	C ₂ H ₅ -O-CH ₂ -HC ₂ OH	20	●	●	●	●	●	●	●	●	0.93
		40	●	●	●	●	●	●	●	●	
		60	●	●	●	●	●	●	●	●	
Chloric acid 10%	HClO ₃	20	●	●	●	●	●	●	●	●	
		40	●	●	●	●	●	●	●	●	
		60	●	●	●	●	●	●	●	●	
Chlorinated water SS	Cl ₂ + H ₂ O	20	●	●	●	●	●	●	●	●	
		40	●	●	●	●	●	●	●	●	
		60	●	●	●	●	●	●	●	●	
Chlorite bleach 5%	NaClO ₂	20	●	●	●	●	●	●	●	●	
		40	●	●	●	●	●	●	●	●	
		60	●	●	●	●	●	●	●	●	
Chloroacetic acid 85%	C ₂ H ₃ ClO ₂	20	●	●	●	●	●	●	●	●	1.36
		40	●	●	●	●	●	●	●	●	
		60	●	●	●	●	●	●	●	●	

C = commercial composition, SS = saturated solution, TP = technically pure; ● = resistant, ● = conditionally resistant, ● = not resistant

Description/formula		Temperature °C	PP	PVDF	Stainless steel 1.4571	Hastelloy C4 2.4610	FKM	EPDM	PTFE/FEP	FFKM	Density kg/dm ³
Chloroacetic acid 98%	C ₂ H ₃ ClO ₂	20	●	●	●	●	●	●	●	●	
		40	●	●	●	●	●	●	●	●	
		60	●	●	●	●	●	●	●	●	
Chlorobenzene TP	C ₆ H ₅ Cl	20	●	●	●	●	●	●	●	●	1.11
		40	●	●	●	●	●	●	●	●	
		60	●	●	●	●	●	●	●	●	
Chlorobutane TP	C ₄ H ₉ Cl	20	●	●	●	●	●	●	●	●	0.89
		40	●	●	●	●	●	●	●	●	
		60	●	●	●	●	●	●	●	●	
Chlorodiphenyl TP	C ₁₂ H ₉ Cl	20	●	●	●	●	●	●	●		
Chloroethane TP	C ₂ H ₅ Cl	20	●	●	●	●	●	●	●	0.92	
Chloroethanol TP	ClH ₂ C-CH ₂ OH	20	●	●	●	●	●	●	●	●	1.20
		40	●	●	●	●	●	●	●	●	
		60	●	●	●	●	●	●	●	●	
Chloroform TP	CHCl ₃	20	●	●	●	●	●	●	●	1.48	
Chlorosulphuric acid TP	HOSO ₂ Cl	20	●	●	●	●	●	●	●	1.77	
Chlorothene TP	C ₂ H ₃ Cl ₃	20	●	●	●	●	●	●	●	1.34	
Chlorotoluene	C ₆ H ₅ -CH ₂ Cl	20	●	●	●	●	●	●	●	●	1.11
		40	●	●	●	●	●	●	●	●	
		60	●	●	●	●	●	●	●	●	
Chromic acid 30%	CrO ₃ +H ₂ O	20	●	●	●	●	●	●	●		
Chromic acid 50%	CrO ₃ +H ₂ O	20	●	●	●	●	●	●	●	●	
		40	●	●	●	●	●	●	●	●	
		60	●	●	●	●	●	●	●	●	
Chromium trioxide 30%	CrO ₃ +H ₂ O	20	●	●	●	●	●	●	●		
Chromium trioxide 50%	CrO ₃ +H ₂ O	20	●	●	●	●	●	●	●	●	
		40	●	●	●	●	●	●	●	●	
		60	●	●	●	●	●	●	●	●	
Chromosulphuric acid 50%	H ₂ SO ₄ +H ₂ O+CrO ₃	20	●	●	●	●	●	●	●	●	
		40	●	●	●	●	●	●	●	●	
		60	●	●	●	●	●	●	●	●	
Citric acid 50%	C ₆ H ₈ O ₇	20	●	●	●	●	●	●	●	●	1.22
		40	●	●	●	●	●	●	●	●	
		60	●	●	●	●	●	●	●	●	
Clophen TP	C ₁₂ H ₉ Cl	20	●	●	●	●	●	●	●		
Clove oil		20	●	●	●	●	●	●	●	●	
		40	●	●	●	●	●	●	●	●	
		60	●	●	●	●	●	●	●	●	
Cooking oil C		20	●	●	●	●	●	●	●	●	
		40	●	●	●	●	●	●	●	●	
		60	●	●	●	●	●	●	●	●	
Copper acetate 50%	(CH ₃ CO ₂) ₂ Cu	20	●	●	●	●	●	●	●	●	
		40	●	●	●	●	●	●	●	●	

C = commercial composition, SS = saturated solution, TP = technically pure; ● = resistant, ● = conditionally resistant, ● = not resistant

Description/formula		Temperature °C	PP	PVDF	Stainless steel 1.4571	Hastelloy C4 2.4610	FKM	EPDM	PTFE/FEP	FFKM	Density kg/dm ³
Copper acetate 50%	(CH ₃ CO ₂) ₂ Cu	60	●	●	●	●	●	●	●	●	
Copper nitrate 25%	Cu(NO ₃) ₂	20	●	●	●	●	●	●	●	●	1.25
		40	●	●	●	●	●	●	●	●	
		60	●	●	●	●	●	●	●	●	
Copper sulphate 18%	CuSO ₄	20	●	●	●	●	●	●	●	●	1.21
		40	●	●	●	●	●	●	●	●	
		60	●	●	●	●	●	●	●	●	
Copper sulphate SS	CuSO ₄	20	●	●	●	●	●	●	●	●	
		40	●	●	●	●	●	●	●	●	
		60	●	●	●	●	●	●	●	●	
Copper(I) chloride 10%	CuCl	20	●	●	●	●	●	●	●	●	
		40	●	●	●	●	●	●	●	●	
		60	●	●	●	●	●	●	●	●	
Copper(II) chloride 20%	CuCl ₂	20	●	●	●	●	●	●	●	●	1.21
		40	●	●	●	●	●	●	●	●	
		60	●	●	●	●	●	●	●	●	
Crotonaldehyde TP	C ₄ H ₆ O	20	●	●	●	●	●	●	●		
Crude oil		20	●	●	●	●	●	●	●	●	
		40	●	●	●	●	●	●	●	●	
		60	●	●	●	●	●	●	●	●	
Cuprous chloride 20%	CuCl	20	●	●	●	●	●	●	●	●	
		40	●	●	●	●	●	●	●	●	
		60	●	●	●	●	●	●	●	●	
Cyclohexane TP	C ₆ H ₁₂	20	●	●	●	●	●	●	●	●	0.78
		40	●	●	●	●	●	●	●	●	
		60	●	●	●	●	●	●	●	●	
Cyclohexanol TP	C ₆ H ₁₂ O	20	●	●	●	●	●	●	●	●	0.94
		40	●	●	●	●	●	●	●	●	
Cyclohexanone TP	C ₆ H ₁₀ O	20	●	●	●	●	●	●	●	0.95	
Decahydronaphthalene TP	C ₁₀ H ₁₈	20	●	●	●	●	●	●	●	●	0.88
		40	●	●	●	●	●	●	●	●	
		60	●	●	●	●	●	●	●	●	
Decalin TP	C ₁₀ H ₁₈	20	●	●	●	●	●	●	●	●	0.88
		40	●	●	●	●	●	●	●	●	
		60	●	●	●	●	●	●	●	●	
Dextrin 18%	C ₆ H ₁₀ O ₅ +H ₂ O	20	●	●	●	●	●	●	●	●	
		40	●	●	●	●	●	●	●	●	
		60	●	●	●	●	●	●	●	●	
Dextrin SS	C ₆ H ₁₀ O ₅ +H ₂ O	20	●	●	●	●	●	●	●		
Dextronic acid	C ₆ H ₁₂ O ₇	20	●	●	●	●	●	●	●	●	
		40	●	●	●	●	●	●	●	●	
		60	●	●	●	●	●	●	●	●	
Diacetone alcohol TP	(CH ₃) ₂ C(OH)CH ₂ COCH ₃	20	●	●	●	●	●	●	●		

C = commercial composition, SS = saturated solution, TP = technically pure; ● = resistant, ● = conditionally resistant, ● = not resistant

Description/formula		Temperature °C	PP	PVDF	Stainless steel 1.4571	Hastelloy C4 2.4610	FKM	EPDM	PTFE/FEP	FFKM	Density kg/dm ³
Diacetone alcohol TP	(CH ₃) ₂ C(OH)CH ₂ COCH ₃	40	●	●	●	●	●	●	●	●	
		60	●	●	●	●	●	●	●	●	
Diamide hydrate TP	H ₂ N-NH ₂	20	●	●	●	●	●	●	●	●	1.08
		40	●	●	●	●	●	●	●	●	
		60	●	●	●	●	●	●	●	●	
Dibromoethane TP	CH ₂ Br-CH ₂ Br	20	●	●	●	●	●	●	●	●	2.18
		40	●	●	●	●	●	●	●	●	
		60	●	●	●	●	●	●	●	●	
Dibutyl ether TP	C ₈ H ₁₈ O	20	●	●	●	●	●	●	●	●	0.77
		40	●	●	●	●	●	●	●	●	
		60	●	●	●	●	●	●	●	●	
Dibutyl phthalate TP	C ₆ H ₄ (CO ₂ C ₄ H ₉) ₂	20	●	●	●	●	●	●	●	●	1.05
		40	●	●	●	●	●	●	●	●	
		60	●	●	●	●	●	●	●	●	
Dibutyl sebacate TP	C ₁₈ H ₃₄ O ₄	20	●	●	●	●	●	●	●	●	0.94
		40	●	●	●	●	●	●	●	●	
		60	●	●	●	●	●	●	●	●	
Dichloroacetic acid TP	CHCl ₂ CO ₂ H	20	●	●	●	●	●	●	●	●	1.56
		40	●	●	●	●	●	●	●	●	
		60	●	●	●	●	●	●	●	●	
Dichloroethane	H ₃ C-CHCl ₂	20	●	●	●	●	●	●	●	●	1.20
		40	●	●	●	●	●	●	●	●	
		60	●	●	●	●	●	●	●	●	
Dichloroethylene 1,1 TP	C ₂ H ₂ Cl ₂	20	●	●	●	●	●	●	●	●	1.22
		40	●	●	●	●	●	●	●	●	
		60	●	●	●	●	●	●	●	●	
Dichlorofluoromethane TP	CF ₂ Cl ₂	20	●	●	●	●	●	●	●	1.32	
Dichloromethane	CH ₂ Cl ₂	20	●	●	●	●	●	●	●	●	1.33
		40	●	●	●	●	●	●	●	●	
Diesel C		20	●	●	●	●	●	●	●	●	
		40	●	●	●	●	●	●	●	●	
		60	●	●	●	●	●	●	●	●	
Diethanolamine	HN(CH ₂ CH ₂ OH) ₂	20	●	●	●	●	●	●	●	●	1.10
		40	●	●	●	●	●	●	●	●	
		60	●	●	●	●	●	●	●	●	
Diethyl cellosolve TP	C ₂ H ₅ -O-CH ₂ -HC ₂ OH	20	●	●	●	●	●	●	●	●	0.93
		40	●	●	●	●	●	●	●	●	
		60	●	●	●	●	●	●	●	●	
Diethyl ether TP	(C ₂ H ₅) ₂ O	20	●	●	●	●	●	●	●	0.71	
Diethylamine 10%	C ₄ H ₁₁ N	20	●	●	●	●	●	●	●	0.70	
Diethylene oxide TP	C ₄ H ₈ O	20	●	●	●	●	●	●	●	●	0.89
		40	●	●	●	●	●	●	●	●	
		60	●	●	●	●	●	●	●	●	

C = commercial composition, SS = saturated solution, TP = technically pure; ● = resistant, ● = conditionally resistant, ● = not resistant

Description/formula		Temperature °C	PP	PVDF	Stainless steel 1.4571	Hastelloy C4 2.4610	FKM	EPDM	PTFE/FEP	FFKM	Density kg/dm ³
Diglycolic acid 30%	C ₂ H ₆ O ₆	20	●	●	●	●	●	●	●	●	
		40	●	●	●	●	●	●	●	●	
		60	●	●	●	●	●	●	●	●	
Diglycolic acid SS	C ₄ H ₆ O ₆	20	●	●	●	●	●	●	●	●	
		40	●	●	●	●	●	●	●	●	
		60	●	●	●	●	●	●	●	●	
Diisobutyl ketone TP	C ₉ H ₁₈ O	20	●	●	●	●	●	●	●	●	
		40	●	●	●	●	●	●	●	●	
		60	●	●	●	●	●	●	●	●	
Diisopropyl ether TP	C ₆ H ₁₄ O	20	●	●	●	●	●	●	●	●	0.73
		40	●	●	●	●	●	●	●	●	
		60	●	●	●	●	●	●	●	●	
Dimethyl phthalate (DMP) TP	C ₆ H ₄ (COOCH ₃) ₂	20	●	●	●	●	●	●	●	●	
		40	●	●	●	●	●	●	●	●	
		60	●	●	●	●	●	●	●	●	
Dimethyl-4-heptanone 2,6 TP	C ₉ H ₁₈ O	20	●	●	●	●	●	●	●	●	
		40	●	●	●	●	●	●	●	●	
		60	●	●	●	●	●	●	●	●	
Dimethylamine TP	(CH ₃) ₂ NH	20	●	●	●	●	●	●	●	0.73	
Dimethylbenzene TP	C ₆ H ₄ (CH ₃) ₂	20	●	●	●	●	●	●	●	●	0.86
		40	●	●	●	●	●	●	●	●	
		60	●	●	●	●	●	●	●	●	
Dimethylformamide (DMF) TP	C ₃ H ₇ NO	20	●	●	●	●	●	●	●	●	0.95
		40	●	●	●	●	●	●	●	●	
		60	●	●	●	●	●	●	●	●	
Dinonyl phthalate TP	C ₂₆ H ₄₂ O ₄	20	●	●	●	●	●	●	●	●	
		30	●	●	●	●	●	●	●	●	
Diocetyl phthalate TP	C ₂₄ H ₃₈ O ₄	20	●	●	●	●	●	●	●	●	
		40	●	●	●	●	●	●	●	●	
		60	●	●	●	●	●	●	●	●	
Dioxane TP	C ₄ H ₆ O ₂	20	●	●	●	●	●	●	●	●	1.03
		40	●	●	●	●	●	●	●	●	
		60	●	●	●	●	●	●	●	●	
DMF TP	C ₃ H ₇ NO	20	●	●	●	●	●	●	●	●	0.95
		40	●	●	●	●	●	●	●	●	
		60	●	●	●	●	●	●	●	●	
DMP TP	C ₆ H ₄ (COOCH ₃) ₂	20	●	●	●	●	●	●	●	●	
		40	●	●	●	●	●	●	●	●	
		60	●	●	●	●	●	●	●	●	
Epichlorohydrin	H ₂ C-O-CH-CH ₂ Cl	20	●	●	●	●	●	●	●	●	
		40	●	●	●	●	●	●	●	●	
		60	●	●	●	●	●	●	●	●	
Epsom salt 10%	MgSO ₄	20	●	●	●	●	●	●	●	●	
		40	●	●	●	●	●	●	●	●	
		60	●	●	●	●	●	●	●	●	

C = commercial composition, SS = saturated solution, TP = technically pure; ● = resistant, ● = conditionally resistant, ● = not resistant

Description/formula		Temperature °C	PP	PVDF	Stainless steel 1.4571	Hastelloy C4 2.4610	FKM	EPDM	PTFE/FEP	FFKM	Density kg/dm ³
Epsom salt SS	MgSO ₄	20	●	●	●	●	●	●	●	●	1.28
		40	●	●	●	●	●	●	●	●	
		60	●	●	●	●	●	●	●	●	
Essential oils		20	●	●	●	●	●	●	●	●	
		40	●	●	●	●	●	●	●	●	
		60	●	●	●	●	●	●	●	●	
Ethanal 40%	CH ₃ -CHO	20	●	●	●	●	●	●	●	●	
		40	●	●	●	●	●	●	●	●	
		60	●	●	●	●	●	●	●	●	
Ethanal TP	CH ₃ -CHO	20	●	●	●	●	●	●	●	●	0.79
		40	●	●	●	●	●	●	●	●	
Ethane diacid 10%	(CO ₂ H) ₂	20	●	●	●	●	●	●	●	●	
		40	●	●	●	●	●	●	●	●	
		60	●	●	●	●	●	●	●	●	
Ethane diacid SS	(CO ₂ H) ₂	20	●	●	●	●	●	●	●	●	1.65
		40	●	●	●	●	●	●	●	●	
		60	●	●	●	●	●	●	●	●	
Ethane dicarboxylic acid 50%	C ₄ H ₆ O ₄	20	●	●	●	●	●	●	●	●	1.06
		40	●	●	●	●	●	●	●	●	
		60	●	●	●	●	●	●	●	●	
Ethanol TP	CH ₃ -CH ₂ -OH	20	●	●	●	●	●	●	●	●	0.79
		40	●	●	●	●	●	●	●	●	
		60	●	●	●	●	●	●	●	●	
Ether TP	(C ₂ H ₅) ₂ O	20	●	●	●	●	●	●	●	0.71	
Ethyl acetate	H ₃ C-COOC ₂ H ₅	20	●	●	●	●	●	●	●	●	0.90
		40	●	●	●	●	●	●	●	●	
		60	●	●	●	●	●	●	●	●	
Ethyl acetate TP	H ₃ C-COOC ₂ H ₅	20	●	●	●	●	●	●	●	●	0.90
		40	●	●	●	●	●	●	●	●	
		60	●	●	●	●	●	●	●	●	
Ethyl alcohol TP	CH ₃ -CH ₂ -OH	20	●	●	●	●	●	●	●	●	0.79
		40	●	●	●	●	●	●	●	●	
		60	●	●	●	●	●	●	●	●	
Ethyl chloride TP	C ₂ H ₅ Cl	20	●	●	●	●	●	●	●	0.92	
Ethyl chloroacetate	ClH ₂ C-CO-OC ₂ H ₅	20	●	●	●	●	●	●	●	●	
		40	●	●	●	●	●	●	●	●	
		60	●	●	●	●	●	●	●	●	
Ethyl ether TP	(C ₂ H ₅) ₂ O	20	●	●	●	●	●	●	●	0.71	
Ethyl fluid TP	Pb(C ₂ H ₅) ₄	20	●	●	●	●	●	●	●	1.66	
Ethyl glycol TP	C ₂ H ₅ -O-CH ₂ -HC ₂ OH	20	●	●	●	●	●	●	●	●	0.93
		40	●	●	●	●	●	●	●	●	
		60	●	●	●	●	●	●	●	●	
Ethylbenzene TP	C ₆ H ₅ -C ₂ H ₅	20	●	●	●	●	●	●	●	0.87	

C = commercial composition, SS = saturated solution, TP = technically pure; ● = resistant, ● = conditionally resistant, ● = not resistant

Description/formula		Temperature °C	PP	PVDF	Stainless steel 1.4571	Hastelloy C4 2.4610	FKM	EPDM	PTFE/FEP	FFKM	Density kg/dm³
Ethylbenzene TP	C ₆ H ₅ -C ₂ H ₅	40	●	●	●	●	●	●	●	●	
		60	●	●	●	●	●	●	●	●	
Ethylene bromide TP	CH ₂ Br-CH ₂ Br	20	●	●	●	●	●	●	●	●	2.18
		40	●	●	●	●	●	●	●	●	
		60	●	●	●	●	●	●	●	●	
Ethylene chloride	H ₃ C-CHCl ₂	20	●	●	●	●	●	●	●	●	1.20
		40	●	●	●	●	●	●	●	●	
		60	●	●	●	●	●	●	●	●	
Ethylene chlorohydrin TP	ClH ₂ C-CH ₂ OH	20	●	●	●	●	●	●	●	●	1.20
		40	●	●	●	●	●	●	●	●	
		60	●	●	●	●	●	●	●	●	
Ethylene dicarboxylic acid 35%	C ₄ H ₄ O ₄	20	●	●	●	●	●	●	●	●	
		40	●	●	●	●	●	●	●	●	
Ethylene dicarboxylic acid SS	C ₄ H ₄ O ₄	20	●	●	●	●	●	●	●	●	
		40	●	●	●	●	●	●	●	●	
		60	●	●	●	●	●	●	●	●	
Ethylene glycol TP	C ₂ H ₆ O ₂	20	●	●	●	●	●	●	●	●	1.11
		40	●	●	●	●	●	●	●	●	
		60	●	●	●	●	●	●	●	●	
Ethylenediamine TP	H ₂ N-CH ₂ -CH ₂ -NH ₂	20	●	●	●	●	●	●	●	●	0.98
		40	●	●	●	●	●	●	●	●	
		60	●	●	●	●	●	●	●	●	
Fatty acids 100%	C ₁₇ H ₃₅ CO ₂ H	20	●	●	●	●	●	●	●	●	0.90
		40	●	●	●	●	●	●	●	●	
		60	●	●	●	●	●	●	●	●	
Ferric chloride 10%	FeCl ₂ +H ₂ O	20	●	●	●	●	●	●	●	●	1.09
		40	●	●	●	●	●	●	●	●	
		60	●	●	●	●	●	●	●	●	
Ferric chloride 50%	FeCl ₂ +H ₂ O	20	●	●	●	●	●	●	●	●	
		40	●	●	●	●	●	●	●	●	
		60	●	●	●	●	●	●	●	●	
Ferro TP	Fe(NO ₃) ₂	20	●	●	●	●	●	●	●	●	
		40	●	●	●	●	●	●	●	●	
		60	●	●	●	●	●	●	●	●	
Fluorosilicic acid 32%	H ₂ SiF ₆	20	●	●	●	●	●	●	●	●	1.17
		40	●	●	●	●	●	●	●	●	
		60	●	●	●	●	●	●	●	●	
Formaldehyde 10%	CH ₂ O+H ₂ O	20	●	●	●	●	●	●	●	●	
		40	●	●	●	●	●	●	●	●	
		60	●	●	●	●	●	●	●	●	
Formaldehyde 35%	CH ₂ O+H ₂ O	20	●	●	●	●	●	●	●	●	1.10
		40	●	●	●	●	●	●	●	●	
Formaldehyde 40%	CH ₂ O+H ₂ O	20	●	●	●	●	●	●	●	●	
		40	●	●	●	●	●	●	●	●	
Formalin 10%	CH ₂ O+H ₂ O	20	●	●	●	●	●	●	●		

C = commercial composition, SS = saturated solution, TP = technically pure; ● = resistant, ● = conditionally resistant, ● = not resistant

Description/formula		Temperature °C	PP	PVDF	Stainless steel 1.4571	Hastelloy C4 2.4610	FKM	EPDM	PTFE/FEP	FFKM	Density kg/dm ³
Formalin 10%	CH ₂ O+H ₂ O	40	●	●	●	●	●	●	●	●	
		60	●	●	●	●	●	●	●	●	
Formalin 35%	CH ₂ O+H ₂ O	20	●	●	●	●	●	●	●	●	1.10
Formalin 40%	CH ₂ O+H ₂ O	20	●	●	●	●	●	●	●	●	
Formamide 100%	HCONH ₂	20	●	●	●	●	●	●	●	●	
		40	●	●	●	●	●	●	●	●	
		60	●	●	●	●	●	●	●	●	
Formic acid 50%	HCOOH	20	●	●	●	●	●	●	●	●	
		40	●	●	●	●	●	●	●	●	
		60	●	●	●	●	●	●	●	●	
Formic acid 85%	HCOOH	20	●	●	●	●	●	●	●	●	1.22
		40	●	●	●	●	●	●	●	●	
		60	●	●	●	●	●	●	●	●	
Freon 12 TP	CF ₂ Cl ₂	20	●	●	●	●	●	●	●	1.32	
Fruit juices C		20	●	●	●	●	●	●	●	●	
		40	●	●	●	●	●	●	●	●	
		60	●	●	●	●	●	●	●	●	
Furfuryl alcohol TP	C ₅ H ₆ O ₂	20	●	●	●	●	●	●	●	●	1.13
		40	●	●	●	●	●	●	●	●	
		60	●	●	●	●	●	●	●	●	
Gallic acid 50%	C ₆ H ₂ (OH) ₃ CO ₂ H	20	●	●	●	●	●	●	●	●	1.05
Glacial acetic acid 10%	CH ₃ COOH	20	●	●	●	●	●	●	●	●	
		40	●	●	●	●	●	●	●	●	
		60	●	●	●	●	●	●	●	●	
Glacial acetic acid 25%	CH ₃ COOH	20	●	●	●	●	●	●	●	●	
		40	●	●	●	●	●	●	●	●	
		60	●	●	●	●	●	●	●	●	
Glacial acetic acid 50%	CH ₃ COOH	20	●	●	●	●	●	●	●	●	
		40	●	●	●	●	●	●	●	●	
		60	●	●	●	●	●	●	●	●	
Glacial acetic acid 80%	CH ₃ COOH	20	●	●	●	●	●	●	●	●	
		40	●	●	●	●	●	●	●	●	
		60	●	●	●	●	●	●	●	●	
Glacial acetic acid 100%	CH ₃ COOH	20	●	●	●	●	●	●	●	●	
		40	●	●	●	●	●	●	●	●	
		60	●	●	●	●	●	●	●	●	
Glass etching ink 50%	(NH ₄)HF ₂	20	●	●	●	●	●	●	●	●	
		40	●	●	●	●	●	●	●	●	
		60	●	●	●	●	●	●	●	●	
Glauber's salt 50%	Na ₂ SO ₄	20	●	●	●	●	●	●	●	●	
		40	●	●	●	●	●	●	●	●	
		60	●	●	●	●	●	●	●	●	
Gluconic acid	C ₆ H ₁₂ O ₇	20	●	●	●	●	●	●	●		



C = commercial composition, SS = saturated solution, TP = technically pure; ● = resistant, ● = conditionally resistant, ● = not resistant

Description/formula		Temperature °C	PP	PVDF	Stainless steel 1.4571	Hastelloy C4 2.4610	FKM	EPDM	PTFE/FEP	FFKM	Density kg/dm ³
Gluconic acid	C ₆ H ₁₂ O ₇	40	●	●	●	●	●	●	●	●	
		60	●	●	●	●	●	●	●	●	
Glucose solution SS	C ₆ H ₁₂ O ₆	20	●	●	●	●	●	●	●	●	1.13
		40	●	●	●	●	●	●	●	●	
		60	●	●	●	●	●	●	●	●	
Glucose SS	C ₆ H ₁₂ O ₆	20	●	●	●	●	●	●	●	●	1.13
		40	●	●	●	●	●	●	●	●	
		60	●	●	●	●	●	●	●	●	
Glucose TP	C ₃ H ₆ O ₃	20	●	●	●	●	●	●	●	●	1.26
		40	●	●	●	●	●	●	●	●	
		60	●	●	●	●	●	●	●	●	
Glycerine TP	C ₃ H ₈ O ₃	20	●	●	●	●	●	●	●	●	1.26
		40	●	●	●	●	●	●	●	●	
		60	●	●	●	●	●	●	●	●	
Glycol ether			●	●	●	●	●	●	●		
Glycol TP	C ₂ H ₆ O ₂	20	●	●	●	●	●	●	●	●	1.11
		40	●	●	●	●	●	●	●	●	
		60	●	●	●	●	●	●	●	●	
Glycolic acid 37%	C ₂ H ₄ O ₃	20	●	●	●	●	●	●	●		
Glycolic acid 70%	C ₂ H ₄ O ₃	20	●	●	●	●	●	●	●	●	
		40	●	●	●	●	●	●	●	●	
		60	●	●	●	●	●	●	●	●	
Goslarite 10%	ZnSO ₄	20	●	●	●	●	●	●	●	●	1.11
		40	●	●	●	●	●	●	●	●	
		60	●	●	●	●	●	●	●	●	
Goslarite SS	ZnSO ₄	20	●	●	●	●	●	●	●	●	1.38
		40	●	●	●	●	●	●	●	●	
		60	●	●	●	●	●	●	●	●	
Heating oil C		20	●	●	●	●	●	●	●	●	
		40	●	●	●	●	●	●	●	●	
		60	●	●	●	●	●	●	●	●	
Heptane TP	C ₇ H ₁₆	20	●	●	●	●	●	●	●	●	0.68
		40	●	●	●	●	●	●	●	●	
		60	●	●	●	●	●	●	●	●	
Hexafluorosilicic acid 32%	H ₂ SiF ₆	20	●	●	●	●	●	●	●	●	1.17
		40	●	●	●	●	●	●	●	●	
		60	●	●	●	●	●	●	●	●	
Hexahydrobenzene TP	C ₆ H ₁₂	20	●	●	●	●	●	●	●	●	0.78
		40	●	●	●	●	●	●	●	●	
		60	●	●	●	●	●	●	●	●	
Hexalin TP	C ₆ H ₁₂ O	20	●	●	●	●	●	●	●	●	0.94
		40	●	●	●	●	●	●	●	●	
Hexamethylenetetramine 10%	(CH ₂) ₆ N ₄	20	●	●	●	●	●	●	●		

C = commercial composition, SS = saturated solution, TP = technically pure; ● = resistant, ● = conditionally resistant, ● = not resistant

H

Description/formula		Temperature °C	PP	PVDF	Stainless steel 1.4571	Hastelloy C4 2.4610	FKM	EPDM	PTFE/FEP	FFKM	Density kg/dm ³
Hexamethylenetetramine 10%	(CH ₂) ₆ N ₄	40	●	●	●	●	●	●	●	●	
		60	●	●	●	●	●	●	●	●	
Hexamine 10%	(CH ₂) ₆ N ₄	20	●	●	●	●	●	●	●	●	
		40	●	●	●	●	●	●	●	●	
		60	●	●	●	●	●	●	●	●	
Hexane TP	C ₆ H ₁₄	20	●	●	●	●	●	●	●	●	
		40	●	●	●	●	●	●	●	●	
		60	●	●	●	●	●	●	●	●	
Hexanol	C ₆ H ₁₃ OH	20	●	●	●	●	●	●	●	0.82	
Hexyl alcohol	C ₆ H ₁₃ OH	20	●	●	●	●	●	●	●	0.82	
Hydrazine TP	H ₂ N-NH ₂	20	●	●	●	●	●	●	●	●	1.08
		40	●	●	●	●	●	●	●	●	
		60	●	●	●	●	●	●	●	●	
Hydriodic acid TP	HI	20	●	●	●	●	●	●	●	●	
		40	●	●	●	●	●	●	●	●	
		60	●	●	●	●	●	●	●	●	
Hydrobromic acid 10%	HBr + H ₂ O	20	●	●	●	●	●	●	●	●	1.07
		40	●	●	●	●	●	●	●	●	
		60	●	●	●	●	●	●	●	●	
Hydrobromic acid 48%	HBr + H ₂ O	20	●	●	●	●	●	●	●	●	1.44
		40	●	●	●	●	●	●	●	●	
		60	●	●	●	●	●	●	●	●	
Hydrochloric acid 10%	HCl	20	●	●	●	●	●	●	●	●	1.05
		40	●	●	●	●	●	●	●	●	
		60	●	●	●	●	●	●	●	●	
Hydrochloric acid 30%	HCl	20	●	●	●	●	●	●	●	●	1.15
		40	●	●	●	●	●	●	●	●	
		60	●	●	●	●	●	●	●	●	
Concentrated hydrochloric acid	HCl	20	●	●	●	●	●	●	●	●	1.20
		40	●	●	●	●	●	●	●	●	
		60	●	●	●	●	●	●	●	●	
Hydrocyanic acid SS	HCN	20	●	●	●	●	●	●	●	●	
		40	●	●	●	●	●	●	●	●	
		60	●	●	●	●	●	●	●	●	
Hydrofluoric acid 40%	HF	20	●	●	●	●	●	●	●	●	1.06
		40	●	●	●	●	●	●	●	●	
		60	●	●	●	●	●	●	●	●	
Hydrofluoric acid 60%	HF	20	●	●	●	●	●	●	●		
Hydrofluoric acid 70%	HF	20	●	●	●	●	●	●	●	●	1.23
		40	●	●	●	●	●	●	●	●	
		60	●	●	●	●	●	●	●	●	
Hydrogen bromide solution 10%	HBr + H ₂ O	20	●	●	●	●	●	●	●	●	1.07
		40	●	●	●	●	●	●	●	●	

C = commercial composition, SS = saturated solution, TP = technically pure; ● = resistant, ● = conditionally resistant, ● = not resistant

Description/formula		Temperature °C	PP	PVDF	Stainless steel 1.4571	Hastelloy C4 2.4610	FKM	EPDM	PTFE/FEP	FFKM	Density kg/dm³
Hydrogen bromide solution 10%	HBr + H ₂ O	60	●	●	●	●	●	●	●	●	
		20	●	●	●	●	●	●	●	●	1.44
		40	●	●	●	●	●	●	●	●	
		60	●	●	●	●	●	●	●	●	
Hydrogen bromide solution 48%	HBr + H ₂ O	20	●	●	●	●	●	●	●	●	
		40	●	●	●	●	●	●	●	●	
		60	●	●	●	●	●	●	●	●	
Hydrogen cyanide TP	HCN	20	●	●	●	●	●	●	●	0.69	
Hydrogen peroxide 3%	H ₂ O ₂	20	●	●	●	●	●	●	●	●	1.01
		40	●	●	●	●	●	●	●	●	
		60	●	●	●	●	●	●	●	●	
Hydrogen peroxide 10%	H ₂ O ₂	20	●	●	●	●	●	●	●	●	1.04
		40	●	●	●	●	●	●	●	●	
		60	●	●	●	●	●	●	●	●	
Hydrogen peroxide 20%	H ₂ O ₂	20	●	●	●	●	●	●	●	●	1.07
		40	●	●	●	●	●	●	●	●	
		60	●	●	●	●	●	●	●	●	
Hydrogen peroxide 30%	H ₂ O ₂	20	●	●	●	●	●	●	●	●	1.11
		40	●	●	●	●	●	●	●	●	
		60	●	●	●	●	●	●	●	●	
Hydrogen peroxide 90%	H ₂ O ₂	20	●	●	●	●	●	●	●	●	1.42
		40	●	●	●	●	●	●	●	●	
		60	●	●	●	●	●	●	●	●	
Hydroxyacetic acid 37%	C ₂ H ₄ O ₃	20	●	●	●	●	●	●	●	●	
		40	●	●	●	●	●	●	●	●	
		60	●	●	●	●	●	●	●	●	
Hydroxyacetic acid 70%	C ₂ H ₄ O ₃	20	●	●	●	●	●	●	●	●	
		40	●	●	●	●	●	●	●	●	
		60	●	●	●	●	●	●	●	●	
Hydroxybenzene 100%	C ₆ H ₆ O	20	●	●	●	●	●	●	●	●	
		40	●	●	●	●	●	●	●	●	
		60	●	●	●	●	●	●	●	●	
Hydroxybenzene 50%	C ₆ H ₆ O	20	●	●	●	●	●	●	●	●	
		40	●	●	●	●	●	●	●	●	
		60	●	●	●	●	●	●	●	●	
Hydroxybenzene 90%	C ₆ H ₆ O	20	●	●	●	●	●	●	●	●	
		40	●	●	●	●	●	●	●	●	
		60	●	●	●	●	●	●	●	●	
Ink C	Iodine tincture C	20	●	●	●	●	●	●	●	●	1.00
		40	●	●	●	●	●	●	●	●	
		60	●	●	●	●	●	●	●	●	
Iodoform	CHJ ₃	20	●	●	●	●	●	●	●	●	
		40	●	●	●	●	●	●	●	●	
		60	●	●	●	●	●	●	●	●	
Iron gall ink C		20	●	●	●	●	●	●	●	1.00	
Iron vitriol 20%	FeSO ₄	20	●	●	●	●	●	●	●	●	1.21
		40	●	●	●	●	●	●	●	●	

C = commercial composition, SS = saturated solution, TP = technically pure; ● = resistant, ● = conditionally resistant, ● = not resistant

Description/formula		Temperature °C	PP	PVDF	Stainless steel 1.4571	Hastelloy C4 2.4610	FKM	EPDM	PTFE/FEP	FFKM	Density kg/dm³
Iron vitriol 20%	FeSO ₄	60	●	●	●	●	●	●	●	●	
Iron(II) chloride 10%	FeCl ₂ +H ₂ O	20	●	●	●	●	●	●	●	●	1.09
		40	●	●	●	●	●	●	●	●	
		60	●	●	●	●	●	●	●	●	
Iron(II) chloride 50%	FeCl ₂ +H ₂ O	20	●	●	●	●	●	●	●	●	
		40	●	●	●	●	●	●	●	●	
		60	●	●	●	●	●	●	●	●	
Iron(III) chloride 50%	FeCl ₃ +H ₂ O	20	●	●	●	●	●	●	●	●	1.55
		40	●	●	●	●	●	●	●	●	
		60	●	●	●	●	●	●	●	●	
Iron(II) nitrate TP	Fe(NO ₃) ₂	20	●	●	●	●	●	●	●	●	
		40	●	●	●	●	●	●	●	●	
		60	●	●	●	●	●	●	●	●	
Iron(II) sulphate 20%	FeSO ₄	20	●	●	●	●	●	●	●	●	1.21
		40	●	●	●	●	●	●	●	●	
		60	●	●	●	●	●	●	●	●	
Iron(III) sulphate 50%	Fe ₂ (SO ₄) ₃	20	●	●	●	●	●	●	●	●	1.61
		40	●	●	●	●	●	●	●	●	
		60	●	●	●	●	●	●	●	●	
Isobutanol 100%	C ₄ H ₁₀ O	20	●	●	●	●	●	●	●	●	0.81
		40	●	●	●	●	●	●	●	●	
		60	●	●	●	●	●	●	●	●	
Isobutyl alcohol 100%	C ₄ H ₁₀ O	20	●	●	●	●	●	●	●	●	0.81
		40	●	●	●	●	●	●	●	●	
		60	●	●	●	●	●	●	●	●	
Isocyanate		20	●	●	●	●	●	●	●		
Isooctane TP	C ₈ H ₁₈	20	●	●	●	●	●	●	●		
Isooctanol TP	C ₄ H ₉ -CH ₂ (C ₂ H ₅)	20	●	●	●	●	●	●	●	0.83	
Isopropanol TP	C ₃ H ₈ O	20	●	●	●	●	●	●	●	●	
		40	●	●	●	●	●	●	●	●	
		60	●	●	●	●	●	●	●	●	
Isopropyl acetate	C ₅ H ₁₀ O ₂	20	●	●	●	●	●	●	●	0.87	
Isopropyl ether TP	C ₆ H ₁₄ O	20	●	●	●	●	●	●	●	●	0.73
		40	●	●	●	●	●	●	●	●	
		60	●	●	●	●	●	●	●	●	
Javel water 15%	KClO	20	●	●	●	●	●	●	●	●	
		40	●	●	●	●	●	●	●	●	
		60	●	●	●	●	●	●	●	●	
Kerosene TP		20	●	●	●	●	●	●	●	●	0.81
		40	●	●	●	●	●	●	●	●	
		60	●	●	●	●	●	●	●	●	
Lactic acid 10%	C ₃ H ₆ O ₃	20	●	●	●	●	●	●	●	●	
		40	●	●	●	●	●	●	●	●	

C = commercial composition, SS = saturated solution, TP = technically pure; ● = resistant, ● = conditionally resistant, ● = not resistant

J

K

L

Description/formula		Temperature °C	PP	PVDF	Stainless steel 1.4571	Hastelloy C4 2.4610	FKM	EPDM	PTFE/FEP	FFKM	Density kg/dm ³	
Lactic acid 10%	C ₃ H ₅ O ₃	60	●	●	●	●	●	●	●	●		
		Lactic acid 90%	C ₃ H ₅ O ₃	20	●	●	●	●	●	●	●	
				40	●	●	●	●	●	●	●	
				60	●	●	●	●	●	●	●	
Lanolin TP		20	●	●	●	●	●	●	●			
		40	●	●	●	●	●	●	●			
		60	●	●	●	●	●	●	●			
Lauric acid TP	C ₁₂ H ₂₄ O ₂	20	●	●	●	●	●	●	●			
		40	●	●	●	●	●	●	●			
		60	●	●	●	●	●	●	●			
Lead acetate 10%	C ₄ H ₆ O ₄ Pb	20	●	●	●	●	●	●	●			
		40	●	●	●	●	●	●	●			
		60	●	●	●	●	●	●	●			
Lead acetate SS	C ₄ H ₆ O ₄ Pb	20	●	●	●	●	●	●	●			
		40	●	●	●	●	●	●	●			
		60	●	●	●	●	●	●	●			
Lead nitrate 50%	Pb(NO ₃) ₂	20	●	●	●	●	●	●	●			
Linseed oil TP		20	●	●	●	●	●	●	●			
		40	●	●	●	●	●	●	●			
		60	●	●	●	●	●	●	●			
Liquid ammonia SS	NH ₄ OH	20	●	●	●	●	●	●	●			
		40	●	●	●	●	●	●	●			
		60	●	●	●	●	●	●	●			
Lithium chloride 45%	LiCl	20	●	●	●	●	●	●	●	1.30		
		40	●	●	●	●	●	●	●			
		60	●	●	●	●	●	●	●			
Lithium sulphate 25%	LiSO ₄	20	●	●	●	●	●	●	●	1.23		
		40	●	●	●	●	●	●	●			
		60	●	●	●	●	●	●	●			
Magnesium chloride 10%	MgCl ₂	20	●	●	●	●	●	●	●			
		40	●	●	●	●	●	●	●			
		60	●	●	●	●	●	●	●			
Magnesium chloride SS	MgCl ₂	20	●	●	●	●	●	●	●			
		40	●	●	●	●	●	●	●			
		60	●	●	●	●	●	●	●			
Magnesium nitrate 25%	Mg(NO ₃) ₂	20	●	●	●	●	●	●	●	1.21		
		40	●	●	●	●	●	●	●			
		60	●	●	●	●	●	●	●			
Magnesium sulphate 10%	MgSO ₄	20	●	●	●	●	●	●	●			
		40	●	●	●	●	●	●	●			
		60	●	●	●	●	●	●	●			
Magnesium sulphate SS	MgSO ₄	20	●	●	●	●	●	●	●	1.28		
		40	●	●	●	●	●	●	●			

C = commercial composition, SS = saturated solution, TP = technically pure; ● = resistant, ● = conditionally resistant, ● = not resistant

M

Description/formula		Temperature °C	PP	PVDF	Stainless steel 1.4571	Hastelloy C4 2.4610	FKM	EPDM	PTFE/FEP	FFKM	Density kg/dm ³
Magnesium sulphate SS	MgSO ₄	60	●	●	●	●	●	●	●	●	
Maize oil TP		20	●	●	●	●	●	●	●	●	
		40	●	●	●	●	●	●	●	●	
		60	●	●	●	●	●	●	●	●	
Maleic acid 35%	C ₄ H ₄ O ₄	20	●	●	●	●	●	●	●	●	
		40	●	●	●	●	●	●	●	●	
Maleic acid SS	C ₄ H ₄ O ₄	20	●	●	●	●	●	●	●	●	
		40	●	●	●	●	●	●	●	●	
		60	●	●	●	●	●	●	●	●	
Malic acid 50%	HOOC-CH ₂ -CHOH-COOH	20	●	●	●	●	●	●	●	●	
		40	●	●	●	●	●	●	●	●	
		60	●	●	●	●	●	●	●	●	
Manganese(II) chloride 20%	MnCl ₂	20	●	●	●	●	●	●	●	●	1.19
		40	●	●	●	●	●	●	●	●	
		60	●	●	●	●	●	●	●	●	
Manganous chloride 20%	MnCl ₂	20	●	●	●	●	●	●	●	●	1.19
		40	●	●	●	●	●	●	●	●	
		60	●	●	●	●	●	●	●	●	
Mercury cyanide TP	Hg(CN) ₂	20	●	●	●	●	●	●	●	●	
		40	●	●	●	●	●	●	●	●	
		60	●	●	●	●	●	●	●	●	
Mercury nitrate SS	Hg(NO ₃) ₂	20	●	●	●	●	●	●	●	●	
		40	●	●	●	●	●	●	●	●	
		60	●	●	●	●	●	●	●	●	
Methanol TP	CH ₃ OH	20	●	●	●	●	●	●	●	●	
		40	●	●	●	●	●	●	●	●	
		60	●	●	●	●	●	●	●	●	
Methyl acetate 100%	CH ₃ CO ₂ CH ₃	20	●	●	●	●	●	●	●	●	0.93
		40	●	●	●	●	●	●	●	●	
		60	●	●	●	●	●	●	●	●	
Methyl alcohol TP	CH ₃ OH	20	●	●	●	●	●	●	●	●	
		40	●	●	●	●	●	●	●	●	
		60	●	●	●	●	●	●	●	●	
Methyl cyanide TP	CH ₃ -CN	20	●	●	●	●	●	●	●	●	0.78
		40	●	●	●	●	●	●	●	●	
		60	●	●	●	●	●	●	●	●	
Methyl ester 100%	CH ₃ CO ₂ CH ₃	20	●	●	●	●	●	●	●	●	0.93
		40	●	●	●	●	●	●	●	●	
		60	●	●	●	●	●	●	●	●	
Methyl ethyl ketone (MEK) TP	C ₄ H ₈ O	20	●	●	●	●	●	●	●	●	0.81
		40	●	●	●	●	●	●	●	●	
		60	●	●	●	●	●	●	●	●	
Methyl glycol	(CH ₂) ₂ OHOCH ₃	20	●	●	●	●	●	●	●	0.98	

C = commercial composition, SS = saturated solution, TP = technically pure; ● = resistant, ● = conditionally resistant, ● = not resistant

Description/formula		Temperature °C	PP	PVDF	Stainless steel 1.4571	Hastelloy C4 2.4610	FKM	EPDM	PTFE/FEP	FFKM	Density kg/dm ³
Methyl glycol (CH ₂) ₂ OHCH ₃		40	●	●	●	●	●	●	●	●	
		60	●	●	●	●	●	●	●	●	
Methyl isobutyl ketone (MIBK) C ₆ H ₁₁ O		20	●	●	●	●	●	●	●	●	
Methylbenzene C ₇ H ₈		20	●	●	●	●	●	●	●	●	0.87
		40	●	●	●	●	●	●	●	●	
		60	●	●	●	●	●	●	●	●	
Methylcellosolve (CH ₂) ₂ OHCH ₃		20	●	●	●	●	●	●	●	●	0.98
		40	●	●	●	●	●	●	●	●	
		60	●	●	●	●	●	●	●	●	
Methylene chloride CH ₂ Cl ₂		20	●	●	●	●	●	●	●	●	1.33
		40	●	●	●	●	●	●	●	●	
Methylpentanone C ₆ H ₁₁ O		20	●	●	●	●	●	●	●	●	
Methylsulphuric acid 50% H ₂ SO ₄ -CH ₂		20	●	●	●	●	●	●	●	●	
		40	●	●	●	●	●	●	●	●	
		60	●	●	●	●	●	●	●	●	
Methylsulphuric acid TP H ₂ SO ₄ -CH ₂		20	●	●	●	●	●	●	●	●	
		40	●	●	●	●	●	●	●	●	
		60	●	●	●	●	●	●	●	●	
Milk		20	●	●	●	●	●	●	●	●	
Milk of lime 15% Ca(OH) ₂		20	●	●	●	●	●	●	●	●	
		40	●	●	●	●	●	●	●	●	
		60	●	●	●	●	●	●	●	●	
Mineral oils		20	●	●	●	●	●	●	●	●	
		40	●	●	●	●	●	●	●	●	
		60	●	●	●	●	●	●	●	●	
Mineral water		20	●	●	●	●	●	●	●	●	
		40	●	●	●	●	●	●	●	●	
		60	●	●	●	●	●	●	●	●	
Monochloroacetic acid 85% C ₂ H ₃ ClO ₂		20	●	●	●	●	●	●	●	●	1.36
		40	●	●	●	●	●	●	●	●	
		60	●	●	●	●	●	●	●	●	
Monochloroacetic acid 98% C ₂ H ₃ ClO ₂		20	●	●	●	●	●	●	●	●	
		40	●	●	●	●	●	●	●	●	
		60	●	●	●	●	●	●	●	●	
Nail polish remover 10% CH ₃ -CO-CH ₃ +H ₂ O		20	●	●	●	●	●	●	●	●	
		40	●	●	●	●	●	●	●	●	
		60	●	●	●	●	●	●	●	●	
Nail polish remover TP CH ₃ -CO-CH ₃		20	●	●	●	●	●	●	●	●	0.79
		40	●	●	●	●	●	●	●	●	
		60	●	●	●	●	●	●	●	●	
Naphtha		20	●	●	●	●	●	●	●	●	
		40	●	●	●	●	●	●	●	●	
		60	●	●	●	●	●	●	●	●	

C = commercial composition, SS = saturated solution, TP = technically pure; ● = resistant, ● = conditionally resistant, ● = not resistant

Description/formula		Temperature °C	PP	PVDF	Stainless steel 1.4571	Hastelloy C4 2.4610	FKM	EPDM	PTFE/FEP	FFKM	Density kg/dm ³
Naphthenic acid 100%	C ₁₇ H ₃₃ CO ₂ H	20	●	●	●	●	●	●	●	●	0.90
		40	●	●	●	●	●	●	●	●	
		60	●	●	●	●	●	●	●	●	
Nickel chloride 20%	NiCl ₂	20	●	●	●	●	●	●	●	●	1.22
		40	●	●	●	●	●	●	●	●	
		60	●	●	●	●	●	●	●	●	
Nickel nitrate 35%	Ni(NO ₃) ₂	20	●	●	●	●	●	●	●	●	1.38
		40	●	●	●	●	●	●	●	●	
		60	●	●	●	●	●	●	●	●	
Nickel sulphate 10%	NiSO ₄	20	●	●	●	●	●	●	●	●	1.21
		40	●	●	●	●	●	●	●	●	
		60	●	●	●	●	●	●	●	●	
Nicotine	C ₁₀ H ₁₄ N ₂	20	●	●	●	●	●	●	●	●	
Nitratine 45%	NaNO ₃	20	●	●	●	●	●	●	●	●	1.37
		40	●	●	●	●	●	●	●	●	
		60	●	●	●	●	●	●	●	●	
Nitric acid 10%	HNO ₃	20	●	●	●	●	●	●	●	●	1.05
		40	●	●	●	●	●	●	●	●	
		60	●	●	●	●	●	●	●	●	
Nitric acid 30%	HNO ₃	20	●	●	●	●	●	●	●	●	1.18
		40	●	●	●	●	●	●	●	●	
		60	●	●	●	●	●	●	●	●	
Nitric acid 50%	HNO ₃	20	●	●	●	●	●	●	●	●	1.31
		40	●	●	●	●	●	●	●	●	
		60	●	●	●	●	●	●	●	●	
Nitric acid 65%	HNO ₃	20	●	●	●	●	●	●	●	●	1.41
		40	●	●	●	●	●	●	●	●	
		60	●	●	●	●	●	●	●	●	
Nitrobenzene TP	C ₆ H ₅ NO ₂	20	●	●	●	●	●	●	●	●	1.21
		40	●	●	●	●	●	●	●	●	
		60	●	●	●	●	●	●	●	●	
Nitrotoluene TP	C ₆ H ₄ CH ₃ NO ₂	20	●	●	●	●	●	●	●	●	
		40	●	●	●	●	●	●	●	●	
		60	●	●	●	●	●	●	●	●	
Nitrous acid	HNO ₂	20	●	●	●	●	●	●	●	●	
		40	●	●	●	●	●	●	●	●	
		60	●	●	●	●	●	●	●	●	
Nitrous acid 10%	HNO ₃	20	●	●	●	●	●	●	●	●	1.05
		40	●	●	●	●	●	●	●	●	
		60	●	●	●	●	●	●	●	●	
Nitrous acid 30%	HNO ₃	20	●	●	●	●	●	●	●	●	1.18
		40	●	●	●	●	●	●	●	●	
		60	●	●	●	●	●	●	●	●	

C = commercial composition, SS = saturated solution, TP = technically pure; ● = resistant, ● = conditionally resistant, ● = not resistant

Description/formula		Temperature °C	PP	PVDF	Stainless steel 1.4571	Hastelloy C4 2.4610	FKM	EPDM	PTFE/FEP	FFKM	Density kg/dm³
Nitrous acid 50%	HNO ₃	20	●	●	●	●	●	●	●	●	1.31
		40	●	●	●	●	●	●	●	●	
		60	●	●	●	●	●	●	●	●	
Nitrous acid 65%	HNO ₃	20	●	●	●	●	●	●	●	●	1.41
		40	●	●	●	●	●	●	●	●	
		60	●	●	●	●	●	●	●	●	
Octal TP	C ₂₄ H ₃₈ O ₄	20	●	●	●	●	●	●	●	●	
		40	●	●	●	●	●	●	●	●	
		60	●	●	●	●	●	●	●	●	
Octane TP	C ₈ H ₁₈	20	●	●	●	●	●	●	●		
Octanoic acid	CH ₃ (CH ₂) ₆ COOH	20	●	●	●	●	●	●	●	●	0.92
		40	●	●	●	●	●	●	●	●	
		60	●	●	●	●	●	●	●	●	
Oil		20	●	●	●	●	●	●	●	●	
		40	●	●	●	●	●	●	●	●	
		60	●	●	●	●	●	●	●	●	
Oil of mirbane TP	C ₆ H ₅ NO ₂	20	●	●	●	●	●	●	●	●	1.21
		40	●	●	●	●	●	●	●	●	
		60	●	●	●	●	●	●	●	●	
Oleic acid TP	C ₁₈ H ₃₄ O ₂	20	●	●	●	●	●	●	●	●	0.90
		40	●	●	●	●	●	●	●	●	
		60	●	●	●	●	●	●	●	●	
Oleum	H ₂ SO ₄ +SO ₃	20	●	●	●	●	●	●	●		
Oxalic acid 10%	(CO ₂ H) ₂	20	●	●	●	●	●	●	●	●	
		40	●	●	●	●	●	●	●	●	
		60	●	●	●	●	●	●	●	●	
Oxalic acid SS	(CO ₂ H) ₂	20	●	●	●	●	●	●	●	●	1.65
		40	●	●	●	●	●	●	●	●	
		60	●	●	●	●	●	●	●	●	
Oxyacetic acid 2,2 30%	C ₄ H ₆ O ₆	20	●	●	●	●	●	●	●	●	
		40	●	●	●	●	●	●	●	●	
		60	●	●	●	●	●	●	●	●	
Oxyacetic acid 2,2 SS	C ₄ H ₆ O ₆	20	●	●	●	●	●	●	●		
Palatinol C TP	C ₆ H ₄ (CO ₂ C ₄ H ₇) ₂	20	●	●	●	●	●	●	●	●	1.05
		40	●	●	●	●	●	●	●	●	
		60	●	●	●	●	●	●	●	●	
Paraffin oil TP	C _n H _{2n}	20	●	●	●	●	●	●	●	●	0.93
		40	●	●	●	●	●	●	●	●	
		60	●	●	●	●	●	●	●	●	
Pectin		20	●	●	●	●	●	●	●		
Pentanol-1 TP	C ₅ H ₁₁ OH	20	●	●	●	●	●	●	●	●	0.82
		40	●	●	●	●	●	●	●	●	
		60	●	●	●	●	●	●	●	●	

C = commercial composition, SS = saturated solution, TP = technically pure; ● = resistant, ● = conditionally resistant, ● = not resistant

Description/formula		Temperature °C	PP	PVDF	Stainless steel 1.4571	Hastelloy C4 2.4610	FKM	EPDM	PTFE/FEP	FFKM	Density kg/dm ³
Pentyl acetate TP	CH ₃ -COOC ₅ H ₁₁	20	●	●	●	●	●	●	●	●	0.88
		40	●	●	●	●	●	●	●	●	
		60	●	●	●	●	●	●	●	●	
Pentyl chloride TP	CH ₃ (CH ₂) ₄ Cl	20	●	●	●	●	●	●	●	●	0.87
		40	●	●	●	●	●	●	●	●	
Pentyl chloride TP	CH ₃ (CH ₂) ₄ Cl	60	●	●	●	●	●	●	●	●	
		20	●	●	●	●	●	●	●	●	
Peracetic acid TP		40	●	●	●	●	●	●	●	●	
		60	●	●	●	●	●	●	●	●	
		20	●	●	●	●	●	●	●	●	
Perchloric acid 20%	HClO ₄	40	●	●	●	●	●	●	●	●	
		60	●	●	●	●	●	●	●	●	
		20	●	●	●	●	●	●	●	●	
Perchloric acid 50%	HClO ₄	40	●	●	●	●	●	●	●	●	1.40
		60	●	●	●	●	●	●	●	●	
		20	●	●	●	●	●	●	●	●	
Perchloric acid 70%	HClO ₄	40	●	●	●	●	●	●	●	●	1.55
		60	●	●	●	●	●	●	●	●	
		20	●	●	●	●	●	●	●	●	
Perchloric acid SS	HClO ₄	40	●	●	●	●	●	●	●	●	
		60	●	●	●	●	●	●	●	●	
		20	●	●	●	●	●	●	●	●	
Perchloroethylene TP	C ₂ Cl ₄	40	●	●	●	●	●	●	●	●	
		60	●	●	●	●	●	●	●	●	
		20	●	●	●	●	●	●	●	●	
Petrol C		40	●	●	●	●	●	●	●	●	0.73
		60	●	●	●	●	●	●	●	●	
		20	●	●	●	●	●	●	●	●	
Petroleum ether TP		40	●	●	●	●	●	●	●	●	0.69
		60	●	●	●	●	●	●	●	●	
		20	●	●	●	●	●	●	●	●	
Petroleum TP		40	●	●	●	●	●	●	●	●	0.81
		60	●	●	●	●	●	●	●	●	
		20	●	●	●	●	●	●	●	●	
Phenol 100%	C ₆ H ₆ O	40	●	●	●	●	●	●	●	●	
		60	●	●	●	●	●	●	●	●	
		20	●	●	●	●	●	●	●	●	
Phenol 50%	C ₆ H ₆ O	40	●	●	●	●	●	●	●	●	
		60	●	●	●	●	●	●	●	●	
		20	●	●	●	●	●	●	●	●	
Phenol 90%	C ₆ H ₆ O	40	●	●	●	●	●	●	●	●	
		60	●	●	●	●	●	●	●	●	
		20	●	●	●	●	●	●	●	●	
Phosphoric acid 30%	H ₃ PO ₄	20	●	●	●	●	●	●	●	1.18	

C = commercial composition, SS = saturated solution, TP = technically pure; ● = resistant, ● = conditionally resistant, ● = not resistant

Description/formula		Temperature °C	PP	PVDF	Stainless steel 1.4571	Hastelloy C4 2.4610	FKM	EPDM	PTFE/FEP	FFKM	Density kg/dm ³
Phosphoric acid 30%	H ₃ PO ₄	40	●	●	●	●	●	●	●	●	
		60	●	●	●	●	●	●	●	●	
Phosphoric acid 50%	H ₃ PO ₄	20	●	●	●	●	●	●	●	●	
		40	●	●	●	●	●	●	●	●	
		60	●	●	●	●	●	●	●	●	
Phosphoric acid 85%	H ₃ PO ₄	20	●	●	●	●	●	●	●	●	1.69
		40	●	●	●	●	●	●	●	●	
		60	●	●	●	●	●	●	●	●	
Phosphoric acid 95%	H ₃ PO ₄	20	●	●	●	●	●	●	●	●	1.70
		40	●	●	●	●	●	●	●	●	
		60	●	●	●	●	●	●	●	●	
Phosphorus chloride TP	POCl ₃	20	●	●	●	●	●	●	●	●	1.57
		40	●	●	●	●	●	●	●	●	
		60	●	●	●	●	●	●	●	●	
Phosphorus trichloride TP	POCl ₃	20	●	●	●	●	●	●	●	●	1.57
		40	●	●	●	●	●	●	●	●	
		60	●	●	●	●	●	●	●	●	
Phthalic acid 50%	C ₆ H ₄ (COOH) ₂ +H ₂ O	20	●	●	●	●	●	●	●	●	
		40	●	●	●	●	●	●	●	●	
		60	●	●	●	●	●	●	●	●	
Phthalic acid SS	C ₆ H ₄ (COOH) ₂ +H ₂ O	20	●	●	●	●	●	●	●	●	1.59
		40	●	●	●	●	●	●	●	●	
		60	●	●	●	●	●	●	●	●	
Pine needle oil		20	●	●	●	●	●	●	●	●	
		40	●	●	●	●	●	●	●	●	
		60	●	●	●	●	●	●	●	●	
Polyol		20	●	●	●	●	●	●	●	1.78	
Potash SS	K ₂ CO ₃	20	●	●	●	●	●	●	●	●	
		40	●	●	●	●	●	●	●	●	
		60	●	●	●	●	●	●	●	●	
Potassium aluminium sulphate 50%	KAl(SO ₄) ₂ ·H ₂ O	20	●	●	●	●	●	●	●	●	
		40	●	●	●	●	●	●	●	●	
		60	●	●	●	●	●	●	●	●	
Potassium bromate SS	KBrO ₃ +H ₂ O	20	●	●	●	●	●	●	●	●	
		40	●	●	●	●	●	●	●	●	
		60	●	●	●	●	●	●	●	●	
Potassium bromide 10%	KBr + H ₂ O	20	●	●	●	●	●	●	●	●	1.37
		40	●	●	●	●	●	●	●	●	
		60	●	●	●	●	●	●	●	●	
Potassium bromide SS	KBr + H ₂ O	20	●	●	●	●	●	●	●	●	
		40	●	●	●	●	●	●	●	●	
		60	●	●	●	●	●	●	●	●	
Potassium carbonate SS	K ₂ CO ₃	20	●	●	●	●	●	●	●		

C = commercial composition, SS = saturated solution, TP = technically pure; ● = resistant, ● = conditionally resistant, ● = not resistant

Description/formula		Temperature °C	PP	PVDF	Stainless steel 1.4571	Hastelloy C4 2.4610	FKM	EPDM	PTFE/FEP	FFKM	Density kg/dm ³
Potassium carbonate SS	K ₂ CO ₃	40	●	●	●	●	●	●	●	●	
		60	●	●	●	●	●	●	●	●	
Potassium chlorate 50%	KClO ₃	20	●	●	●	●	●	●	●	●	
		40	●	●	●	●	●	●	●	●	
		60	●	●	●	●	●	●	●	●	
Potassium chloride 10%	KCl	20	●	●	●	●	●	●	●	●	
		40	●	●	●	●	●	●	●	●	
		60	●	●	●	●	●	●	●	●	
Potassium chloride SS	KCl	20	●	●	●	●	●	●	●	●	1.17
		40	●	●	●	●	●	●	●	●	
		60	●	●	●	●	●	●	●	●	
Potassium cyanide 50%	KCN	20	●	●	●	●	●	●	●	●	
		40	●	●	●	●	●	●	●	●	
		60	●	●	●	●	●	●	●	●	
Potassium cyanide SS	KCN	20	●	●	●	●	●	●	●	●	1.31
		40	●	●	●	●	●	●	●	●	
		60	●	●	●	●	●	●	●	●	
Potassium dichromate 40%	K ₂ Cr ₂ O ₇	20	●	●	●	●	●	●	●	●	
Potassium ferricyanide 10%	K ₄ Fe(CN) ₆	20	●	●	●	●	●	●	●	●	
		40	●	●	●	●	●	●	●	●	
		60	●	●	●	●	●	●	●	●	
Potassium ferricyanide 20%	K ₄ Fe(CN) ₆	20	●	●	●	●	●	●	●	●	1.11
		40	●	●	●	●	●	●	●	●	
		60	●	●	●	●	●	●	●	●	
Potassium ferricyanide SS	K ₄ Fe(CN) ₆	20	●	●	●	●	●	●	●	●	
		40	●	●	●	●	●	●	●	●	
		60	●	●	●	●	●	●	●	●	
Potassium ferrocyanide 10%	K ₃ Fe(CN) ₆	20	●	●	●	●	●	●	●	●	
		40	●	●	●	●	●	●	●	●	
		60	●	●	●	●	●	●	●	●	
Potassium ferrocyanide 16%	K ₃ Fe(CN) ₆	20	●	●	●	●	●	●	●	●	1.11
		40	●	●	●	●	●	●	●	●	
		60	●	●	●	●	●	●	●	●	
Potassium ferrocyanide SS	K ₃ Fe(CN) ₆	20	●	●	●	●	●	●	●	●	
		40	●	●	●	●	●	●	●	●	
		60	●	●	●	●	●	●	●	●	
Potassium hydroxide 20%	KOH	20	●	●	●	●	●	●	●	●	1.19
		40	●	●	●	●	●	●	●	●	
		60	●	●	●	●	●	●	●	●	
Potassium hydroxide 30%	KOH	20	●	●	●	●	●	●	●	●	1.29
		40	●	●	●	●	●	●	●	●	
		60	●	●	●	●	●	●	●	●	
Potassium hydroxide 60%	KOH	20	●	●	●	●	●	●	●	1.63	

C = commercial composition, SS = saturated solution, TP = technically pure; ● = resistant, ● = conditionally resistant, ● = not resistant

Description/formula		Temperature °C	PP	PVDF	Stainless steel 1.4571	Hastelloy C4 2.4610	FKM	EPDM	PTFE/FEP	FFKM	Density kg/dm ³
Potassium hydroxide 60%	KOH	40	●	●	●	●	●	●	●	●	
		60	●	●	●	●	●	●	●	●	
Potassium hypochlorite 15%	KClO	20	●	●	●	●	●	●	●	●	
		40	●	●	●	●	●	●	●	●	
		60	●	●	●	●	●	●	●	●	
Potassium iodide 50%	KJ	20	●	●	●	●	●	●	●	●	1.55
		40	●	●	●	●	●	●	●	●	
		60	●	●	●	●	●	●	●	●	
Potassium iodide SS	KJ	20	●	●	●	●	●	●	●	●	
		40	●	●	●	●	●	●	●	●	
		60	●	●	●	●	●	●	●	●	
Potassium nitrate 10%	KNO ₃	20	●	●	●	●	●	●	●	●	
		40	●	●	●	●	●	●	●	●	
		60	●	●	●	●	●	●	●	●	
Potassium nitrate 24%	KNO ₃	20	●	●	●	●	●	●	●	●	1.17
		40	●	●	●	●	●	●	●	●	
		60	●	●	●	●	●	●	●	●	
Potassium oxalate	K ₂ (CO ₂) ₂	20	●	●	●	●	●	●	●	●	
		40	●	●	●	●	●	●	●	●	
		60	●	●	●	●	●	●	●	●	
Potassium permanganate 6%	KMnO ₄	20	●	●	●	●	●	●	●	●	1.04
		40	●	●	●	●	●	●	●	●	
		60	●	●	●	●	●	●	●	●	
Potassium permanganate 18%	KMnO ₄	20	●	●	●	●	●	●	●	●	
		40	●	●	●	●	●	●	●	●	
Potassium sulphate 10%	K ₂ SO ₄	20	●	●	●	●	●	●	●	●	1.08
		40	●	●	●	●	●	●	●	●	
		60	●	●	●	●	●	●	●	●	
Propanediol TP	C ₃ H ₈ O ₂	20	●	●	●	●	●	●	●	●	1.04
		40	●	●	●	●	●	●	●	●	
		60	●	●	●	●	●	●	●	●	
Propanol TP	C ₃ H ₈ O	20	●	●	●	●	●	●	●	●	
		40	●	●	●	●	●	●	●	●	
		60	●	●	●	●	●	●	●	●	
Propanone 10%	CH ₃ -CO-CH ₃ +H ₂ O	20	●	●	●	●	●	●	●	●	
		40	●	●	●	●	●	●	●	●	
		60	●	●	●	●	●	●	●	●	
Propanone TP	CH ₃ -CO-CH ₃	20	●	●	●	●	●	●	●	●	0.79
		40	●	●	●	●	●	●	●	●	
		60	●	●	●	●	●	●	●	●	
Propionic acid 50%	C ₃ H ₆ O ₂	20	●	●	●	●	●	●	●	●	
		40	●	●	●	●	●	●	●	●	
		60	●	●	●	●	●	●	●	●	

C = commercial composition, SS = saturated solution, TP = technically pure; ● = resistant, ● = conditionally resistant, ● = not resistant

Description/formula		Temperature °C	PP	PVDF	Stainless steel 1.4571	Hastelloy C4 2.4610	FKM	EPDM	PTFE/FEP	FFKM	Density kg/dm³
Propionic acid TP	$C_3H_6O_2$	20	●	●	●	●	●	●	●	●	0.99
		40	●	●	●	●	●	●	●	●	
		60	●	●	●	●	●	●	●	●	
Propyl acetate	$C_5H_{10}O_2$	20	●	●	●	●	●	●	●	●	0.87
Propylene aldehyde TP	C_4H_6O	20	●	●	●	●	●	●	●	●	
Propylene glycol TP	$C_3H_8O_2$	20	●	●	●	●	●	●	●	●	1.04
		40	●	●	●	●	●	●	●	●	
		60	●	●	●	●	●	●	●	●	
Propylene oxide TP	C_3H_6O	20	●	●	●	●	●	●	●	●	0.83
		40	●	●	●	●	●	●	●	●	
Pyranton TP	$(CH_2)_2C(OH)CH_2COCH_3$	20	●	●	●	●	●	●	●	●	
		40	●	●	●	●	●	●	●	●	
		60	●	●	●	●	●	●	●	●	
Pyridine TP	C_5H_5N	20	●	●	●	●	●	●	●	●	0.99
		40	●	●	●	●	●	●	●	●	
		60	●	●	●	●	●	●	●	●	
Pyrogallic acid 10%	$C_6H_3(OH)_3-1.2.3$	20	●	●	●	●	●	●	●	●	
		40	●	●	●	●	●	●	●	●	
		60	●	●	●	●	●	●	●	●	
Pyrogallol 10%	$C_6H_3(OH)_3-1.2.3$	20	●	●	●	●	●	●	●	●	
		40	●	●	●	●	●	●	●	●	
		60	●	●	●	●	●	●	●	●	
Seawater		20	●	●	●	●	●	●	●	●	
		40	●	●	●	●	●	●	●	●	
		60	●	●	●	●	●	●	●	●	
Silicic acid TP	$Si(OH)_4$	20	●	●	●	●	●	●	●	●	
		40	●	●	●	●	●	●	●	●	
		60	●	●	●	●	●	●	●	●	
Silicone oil TP		20	●	●	●	●	●	●	●	●	1.06
		40	●	●	●	●	●	●	●	●	
		60	●	●	●	●	●	●	●	●	
Silver nitrate 8%	$AgNO_3$	20	●	●	●	●	●	●	●	●	1.07
		40	●	●	●	●	●	●	●	●	
		60	●	●	●	●	●	●	●	●	
Soda 10%	$NaHCO_3$	20	●	●	●	●	●	●	●	●	1.07
		40	●	●	●	●	●	●	●	●	
		60	●	●	●	●	●	●	●	●	
Sodium acetate 10%	CH_3COONa	20	●	●	●	●	●	●	●	●	
		40	●	●	●	●	●	●	●	●	
		60	●	●	●	●	●	●	●	●	
Sodium benzoate 10%	$C_7H_5NaO_2$	20	●	●	●	●	●	●	●	●	
		40	●	●	●	●	●	●	●	●	
		60	●	●	●	●	●	●	●	●	

S

C = commercial composition, SS = saturated solution, TP = technically pure; ● = resistant, ● = conditionally resistant, ● = not resistant

Description/formula		Temperature °C	PP	PVDF	Stainless steel 1.4571	Hastelloy C4 2.4610	FKM	EPDM	PTFE/FEP	FFKM	Density kg/dm ³
Sodium benzoate 36%	C ₇ H ₅ NaO ₂	20	●	●	●	●	●	●	●	●	
		40	●	●	●	●	●	●	●	●	
		60	●	●	●	●	●	●	●	●	
Sodium benzoate SS	C ₇ H ₅ NaO ₂	20	●	●	●	●	●	●	●	●	
		40	●	●	●	●	●	●	●	●	
Sodium bicarbonate 10%	NaHCO ₃	20	●	●	●	●	●	●	●	●	1.07
		40	●	●	●	●	●	●	●	●	
		60	●	●	●	●	●	●	●	●	
Sodium chlorate 25%	NaClO ₃	20	●	●	●	●	●	●	●	●	1.23
		40	●	●	●	●	●	●	●	●	
		60	●	●	●	●	●	●	●	●	
Sodium chloride 20%	NaCl	20	●	●	●	●	●	●	●	●	
		40	●	●	●	●	●	●	●	●	
		60	●	●	●	●	●	●	●	●	
Sodium chlorite 5%	NaClO ₂	20	●	●	●	●	●	●	●	●	
		40	●	●	●	●	●	●	●	●	
		60	●	●	●	●	●	●	●	●	
Sodium dichromate 10%	Na ₂ Cr ₂ O ₇	20	●	●	●	●	●	●	●	●	
		40	●	●	●	●	●	●	●	●	
		60	●	●	●	●	●	●	●	●	
Sodium fluoride 4%	NaF	20	●	●	●	●	●	●	●	●	1.04
		40	●	●	●	●	●	●	●	●	
		60	●	●	●	●	●	●	●	●	
Sodium hydroxide 10%	NaOH	20	●	●	●	●	●	●	●	●	1.16
		40	●	●	●	●	●	●	●	●	
		60	●	●	●	●	●	●	●	●	
Sodium hydroxide 30%	NaOH	20	●	●	●	●	●	●	●	●	1.33
		40	●	●	●	●	●	●	●	●	
		60	●	●	●	●	●	●	●	●	
Sodium hydroxide 50%	NaOH	20	●	●	●	●	●	●	●	●	1.53
		40	●	●	●	●	●	●	●	●	
		60	●	●	●	●	●	●	●	●	
Sodium hypochlorite 10%	NaOCl	20	●	●	●	●	●	●	●		
Sodium hypochlorite 12.5%	NaOCl	20	●	●	●	●	●	●	●	●	
		40	●	●	●	●	●	●	●	●	
Sodium hypochlorite 20%	NaOCl	20	●	●	●	●	●	●	●	●	
		40	●	●	●	●	●	●	●	●	
		60	●	●	●	●	●	●	●	●	
Sodium hyposulphite 40%	Na ₂ S ₂ O ₃	20	●	●	●	●	●	●	●	●	
		40	●	●	●	●	●	●	●	●	
		60	●	●	●	●	●	●	●	●	
Sodium nitrate 45%	NaNO ₃	20	●	●	●	●	●	●	●	●	1.37
		40	●	●	●	●	●	●	●	●	

C = commercial composition, SS = saturated solution, TP = technically pure; ● = resistant, ● = conditionally resistant, ● = not resistant

Description/formula		Temperature °C	PP	PVDF	Stainless steel 1.4571	Hastelloy C4 2.4610	FKM	EPDM	PTFE/FEP	FFKM	Density kg/dm ³	
Sodium nitrate 45%	NaNO ₃	60	●	●	●	●	●	●	●	●		
Sodium nitrite 50%	NaNO ₂	20	●	●	●	●	●	●	●	●		
		40	●	●	●	●	●	●	●	●		
Sodium nitrite 50%	NaNO ₂	60	●	●	●	●	●	●	●	●		
		Sodium perchlorate 25%	NaClO ₄	20	●	●	●	●	●	●	●	1.18
				40	●	●	●	●	●	●	●	●
60	●	●	●	●	●	●	●	●	●			
Sodium silicate 20%	Na ₂ SiO ₃	20	●	●	●	●	●	●	●	●	1.24	
		40	●	●	●	●	●	●	●	●		
		60	●	●	●	●	●	●	●	●		
Sodium sulphate 50%	Na ₂ SO ₄	20	●	●	●	●	●	●	●	●	1.46	
		40	●	●	●	●	●	●	●	●		
		60	●	●	●	●	●	●	●	●		
Sodium sulphite SS	Na ₂ SO ₃	20	●	●	●	●	●	●	●	●	1.18	
		40	●	●	●	●	●	●	●	●		
		60	●	●	●	●	●	●	●	●		
Sodium tetraborate 10%	Na ₂ B ₄ O ₇ +10 H ₂ O	20	●	●	●	●	●	●	●	●	1.03	
		40	●	●	●	●	●	●	●	●		
		60	●	●	●	●	●	●	●	●		
Sodium tetraborate SS	Na ₂ B ₄ O ₇ +10 H ₂ O	20	●	●	●	●	●	●	●	●		
		40	●	●	●	●	●	●	●	●		
		60	●	●	●	●	●	●	●	●		
Sodium thiosulphate 40%	Na ₂ S ₂ O ₃	20	●	●	●	●	●	●	●	●		
		40	●	●	●	●	●	●	●	●		
		60	●	●	●	●	●	●	●	●		
Spindle oil TP		20	●	●	●	●	●	●	●	●		
		40	●	●	●	●	●	●	●	●		
		60	●	●	●	●	●	●	●	●		
Styrene TP	C ₆ H ₅ CHCH ₂	20	●	●	●	●	●	●	●	0.91		
Succinic acid 50%	C ₄ H ₆ O ₄	20	●	●	●	●	●	●	●	●	1.06	
		40	●	●	●	●	●	●	●	●		
		60	●	●	●	●	●	●	●	●		
Sulphite lye 10%	Ca(HSO ₃) ₂	20	●	●	●	●	●	●	●	●		
		Sulphite lye SS	20	●	●	●	●	●	●	●	●	
			40	●	●	●	●	●	●	●	●	
60	●	●	●	●	●	●	●	●				
Sulphur chloride 10%	S ₂ Cl ₂	20	●	●	●	●	●	●	●			
Sulphuric acid 40%	H ₂ SO ₄	20	●	●	●	●	●	●	●	●	1.30	
		40	●	●	●	●	●	●	●	●		
		60	●	●	●	●	●	●	●	●		
Sulphuric acid 80%	H ₂ SO ₄	20	●	●	●	●	●	●	●	●	1.73	
		40	●	●	●	●	●	●	●	●		
		60	●	●	●	●	●	●	●	●		

C = commercial composition, SS = saturated solution, TP = technically pure; ● = resistant, ● = conditionally resistant, ● = not resistant

Description/formula		Temperature °C	PP	PVDF	Stainless steel 1.4571	Hastelloy C4 2.4610	FKM	EPDM	PTFE/FEP	FFKM	Density kg/dm³
Sulphuric acid 90%	H ₂ SO ₄	20	●	●	●	●	●	●	●	●	1.82
		40	●	●	●	●	●	●	●	●	
		60	●	●	●	●	●	●	●	●	
Sulphuric acid 98%	H ₂ SO ₄	20	●	●	●	●	●	●	●	●	1.84
		40	●	●	●	●	●	●	●	●	
		60	●	●	●	●	●	●	●	●	
Sulphurous acid 50%	H ₂ SO ₃	20	●	●	●	●	●	●	●	●	
		40	●	●	●	●	●	●	●	●	
		60	●	●	●	●	●	●	●	●	
Sylvite 10%	KCl	20	●	●	●	●	●	●	●	●	
		40	●	●	●	●	●	●	●	●	
		60	●	●	●	●	●	●	●	●	
Sylvite SS	KCl	20	●	●	●	●	●	●	●	●	1.17
		40	●	●	●	●	●	●	●	●	
		60	●	●	●	●	●	●	●	●	
Table salt 20%	NaCl	20	●	●	●	●	●	●	●	●	
		40	●	●	●	●	●	●	●	●	
		60	●	●	●	●	●	●	●	●	
Tannic acid 50%	C ₂ O ₆ H ₆	20	●	●	●	●	●	●	●	●	
		40	●	●	●	●	●	●	●	●	
		60	●	●	●	●	●	●	●	●	
Tannin 50%	C ₂ O ₆ H ₆	20	●	●	●	●	●	●	●	●	
		40	●	●	●	●	●	●	●	●	
		60	●	●	●	●	●	●	●	●	
Tanning extracts, vegetable C		20	●	●	●	●	●	●	●	●	
		40	●	●	●	●	●	●	●	●	
		60	●	●	●	●	●	●	●	●	
Tartaric acid SS	C ₄ H ₆ O ₆	20	●	●	●	●	●	●	●	●	1.76
		40	●	●	●	●	●	●	●	●	
		60	●	●	●	●	●	●	●	●	
Tetrachloroethane TP	Cl ₂ CH-CHCl ₂	20	●	●	●	●	●	●	●	●	1.60
		40	●	●	●	●	●	●	●	●	
		60	●	●	●	●	●	●	●	●	
Tetrachloroethylene TP	C ₂ Cl ₄	20	●	●	●	●	●	●	●	●	
		40	●	●	●	●	●	●	●	●	
		60	●	●	●	●	●	●	●	●	
Tetraethyl lead TP	Pb(C ₂ H ₅) ₄	20	●	●	●	●	●	●	●	1.66	
Tetrahydrofuran TP	C ₄ H ₈ O	20	●	●	●	●	●	●	●	●	0.89
		40	●	●	●	●	●	●	●	●	
		60	●	●	●	●	●	●	●	●	
Tetrahydronaphthalene 100%	C ₁₀ H ₁₂	20	●	●	●	●	●	●	●	●	0.97
		40	●	●	●	●	●	●	●	●	
		60	●	●	●	●	●	●	●	●	

C = commercial composition, SS = saturated solution, TP = technically pure; ● = resistant, ● = conditionally resistant, ● = not resistant

Description/formula		Temperature °C	PP	PVDF	Stainless steel 1.4571	Hastelloy C4 2.4610	FKM	EPDM	PTFE/FEP	FFKM	Density kg/dm ³
Tetraalin 100%	C ₁₀ H ₁₂	20	●	●	●	●	●	●	●	●	0.97
		40	●	●	●	●	●	●	●	●	
		60	●	●	●	●	●	●	●	●	
Thionyl chloride TP	SOCl ₂	20	●	●	●	●	●	●	●	●	1.66
		40	●	●	●	●	●	●	●	●	
		60	●	●	●	●	●	●	●	●	
Thiophene	C ₄ H ₄ S	20	●	●	●	●	●	●	●		
Tin(II) chloride 20%	SnCl ₂	20	●	●	●	●	●	●	●	●	1.17
		40	●	●	●	●	●	●	●	●	
		60	●	●	●	●	●	●	●	●	
Toluene	C ₇ H ₈	20	●	●	●	●	●	●	●	●	0.87
		40	●	●	●	●	●	●	●	●	
		60	●	●	●	●	●	●	●	●	
Toothpaste C		20	●	●	●	●	●	●	●		
Transformer oil TP		20	●	●	●	●	●	●	●	●	
		40	●	●	●	●	●	●	●	●	
		60	●	●	●	●	●	●	●	●	
Tributyl phosphate TP	C ₁₂ H ₂₇ O ₄ P	20	●	●	●	●	●	●	●	●	0.98
		40	●	●	●	●	●	●	●	●	
		60	●	●	●	●	●	●	●	●	
Trichloroacetic acid 50%	CCl ₃ CO ₂ H	20	●	●	●	●	●	●	●	●	
		40	●	●	●	●	●	●	●	●	
		60	●	●	●	●	●	●	●	●	
Trichloroacetic acid TP	CCl ₃ CO ₂ H	20	●	●	●	●	●	●	●	●	1.62
		40	●	●	●	●	●	●	●	●	
		60	●	●	●	●	●	●	●	●	
Trichlorobenzene	C ₆ H ₃ Cl ₃	20	●	●	●	●	●	●	●	●	
		40	●	●	●	●	●	●	●	●	
		60	●	●	●	●	●	●	●	●	
Trichloroethane TP	C ₂ H ₃ Cl ₃	20	●	●	●	●	●	●	●	1.34	
Trichloroethylene 50%	C ₂ HCl ₃	20	●	●	●	●	●	●	●	●	
		40	●	●	●	●	●	●	●	●	
		60	●	●	●	●	●	●	●	●	
Trichloroethylene TP	C ₂ HCl ₃	20	●	●	●	●	●	●	●	●	1.47
		40	●	●	●	●	●	●	●	●	
		60	●	●	●	●	●	●	●	●	
Trichloromethane TP	CHCl ₃	20	●	●	●	●	●	●	●	1.48	
Trichlorophenol	C ₆ H ₃ Cl ₃	20	●	●	●	●	●	●	●	●	
		40	●	●	●	●	●	●	●	●	
		60	●	●	●	●	●	●	●	●	
Tricresyl phosphate TP	PO ₄ (C ₆ H ₄ CH ₃) ₃	20	●	●	●	●	●	●	●	●	1.13
		40	●	●	●	●	●	●	●	●	
		60	●	●	●	●	●	●	●	●	

C = commercial composition, SS = saturated solution, TP = technically pure; ● = resistant, ● = conditionally resistant, ● = not resistant

Description/formula		Temperature °C	PP	PVDF	Stainless steel 1.4571	Hastelloy C4 2.4610	FKM	EPDM	PTFE/FEP	FFKM	Density kg/dm³	
Triethylamine TP	C ₂ H ₁₅ N	20	●	●	●	●	●	●	●	●	0.73	
		40	●	●	●	●	●	●	●	●		
		60	●	●	●	●	●	●	●	●		
Trihydroxybenzoic acid 50%	C ₆ H ₂ (OH) ₃ CO ₂ H	20	●	●	●	●	●	●	●	●		
Triol TP	C ₄ H ₁₀ O ₃	20	●	●	●	●	●	●	●	●		
Trisodium phosphate 10%	Na ₃ PO ₄	20	●	●	●	●	●	●	●	●		
		40	●	●	●	●	●	●	●	●		
		60	●	●	●	●	●	●	●	●		
Turpentine oil C		20	●	●	●	●	●	●	●	●	0.86	
		40	●	●	●	●	●	●	●	●		
		60	●	●	●	●	●	●	●	●		
U	Urea 10%	CH ₄ N ₂ O	20	●	●	●	●	●	●	●		
	Urea 33%	CH ₄ N ₂ O	40	●	●	●	●	●	●	●		
		CH ₄ N ₂ O	60	●	●	●	●	●	●	●		
	Urea solution 10%	CH ₄ N ₂ O	40	●	●	●	●	●	●	●		
		CH ₄ N ₂ O	60	●	●	●	●	●	●	●		
	Urea solution 33%	CH ₄ N ₂ O	20	●	●	●	●	●	●	●		
Urine		20	●	●	●	●	●	●	●	●		
		40	●	●	●	●	●	●	●	●		
		60	●	●	●	●	●	●	●	●		
V	Valeric acid 20%	C ₃ H ₇ COOH	20	●	●	●	●	●	●	●	0.88	
	Valeric acid TP	C ₃ H ₇ COOH	20	●	●	●	●	●	●	●	0.96	
	Vinegar C		20	●	●	●	●	●	●	●	●	
			40	●	●	●	●	●	●	●	●	
			60	●	●	●	●	●	●	●	●	
	Vinyl acetate TP	C ₄ H ₆ O ₂	20	●	●	●	●	●	●	●	●	0.93
40			●	●	●	●	●	●	●	●		
60			●	●	●	●	●	●	●	●		
Vinyl carbinol 96%	H ₂ C-CH-CH ₂ -OH	20	●	●	●	●	●	●	●	●	0.87	
		40	●	●	●	●	●	●	●	●		
		60	●	●	●	●	●	●	●	●		
Vinyl cyanide TP	CH ₂ -CH-CN	20	●	●	●	●	●	●	●	●	0.81	
		40	●	●	●	●	●	●	●	●		
		60	●	●	●	●	●	●	●	●		
Vinylbenzene TP	C ₆ H ₅ CHCH ₂	20	●	●	●	●	●	●	●	0.91		
Vinylidene chloride TP	C ₂ H ₂ Cl ₂	20	●	●	●	●	●	●	●	●	1.22	
		40	●	●	●	●	●	●	●	●		
		60	●	●	●	●	●	●	●	●		
W	Water	H ₂ O	20	●	●	●	●	●	●	●	1.00	
			40	●	●	●	●	●	●	●		
			60	●	●	●	●	●	●	●		
Water glass 20%	Na ₂ SiO ₃	20	●	●	●	●	●	●	●	●	1.24	
		40	●	●	●	●	●	●	●	●		
		60	●	●	●	●	●	●	●	●		

C = commercial composition, SS = saturated solution, TP = technically pure; ● = resistant, ● = conditionally resistant, ● = not resistant

Description/formula		Temperature °C	PP	PVDF	Stainless steel 1.4571	Hastelloy C4 2.4610	FKM	EPDM	PTFE/FEP	FFKM	Density kg/dm ³
Water, distilled	H ₂ O	20	●	●	●	●	●	●	●	●	1.00
		40	●	●	●	●	●	●	●	●	
		60	●	●	●	●	●	●	●	●	
White spirit			●	●	●	●	●	●	●		
Wine vinegar C		20	●	●	●	●	●	●	●	●	
		40	●	●	●	●	●	●	●	●	
		60	●	●	●	●	●	●	●	●	
Xylene TP	C ₆ H ₄ (CH ₃) ₂	20	●	●	●	●	●	●	●	●	0.86
		40	●	●	●	●	●	●	●	●	
		60	●	●	●	●	●	●	●	●	
Zinc chloride 20%	ZnCl ₂	20	●	●	●	●	●	●	●	●	1.19
		40	●	●	●	●	●	●	●	●	
		60	●	●	●	●	●	●	●	●	
Zinc chloride 75%	ZnCl ₂	20	●	●	●	●	●	●	●	●	2.07
		40	●	●	●	●	●	●	●	●	
		60	●	●	●	●	●	●	●	●	
Zinc-chloride solution 20%	ZnCl ₂	20	●	●	●	●	●	●	●	●	1.19
		40	●	●	●	●	●	●	●	●	
		60	●	●	●	●	●	●	●	●	
Zinc-chloride solution 75%	ZnCl ₂	20	●	●	●	●	●	●	●	●	2.07
		40	●	●	●	●	●	●	●	●	
		60	●	●	●	●	●	●	●	●	
Zinc sulphate 10%	ZnSO ₄	20	●	●	●	●	●	●	●	●	1.11
		40	●	●	●	●	●	●	●	●	
		60	●	●	●	●	●	●	●	●	
Zinc sulphate SS	ZnSO ₄	20	●	●	●	●	●	●	●	●	1.38
		40	●	●	●	●	●	●	●	●	
		60	●	●	●	●	●	●	●	●	

X

Z

C = commercial composition, SS = saturated solution, TP = technically pure; ● = resistant, ● = conditionally resistant, ● = not resistant

NEOLUTION

The Neolution® in Pump Efficiency.

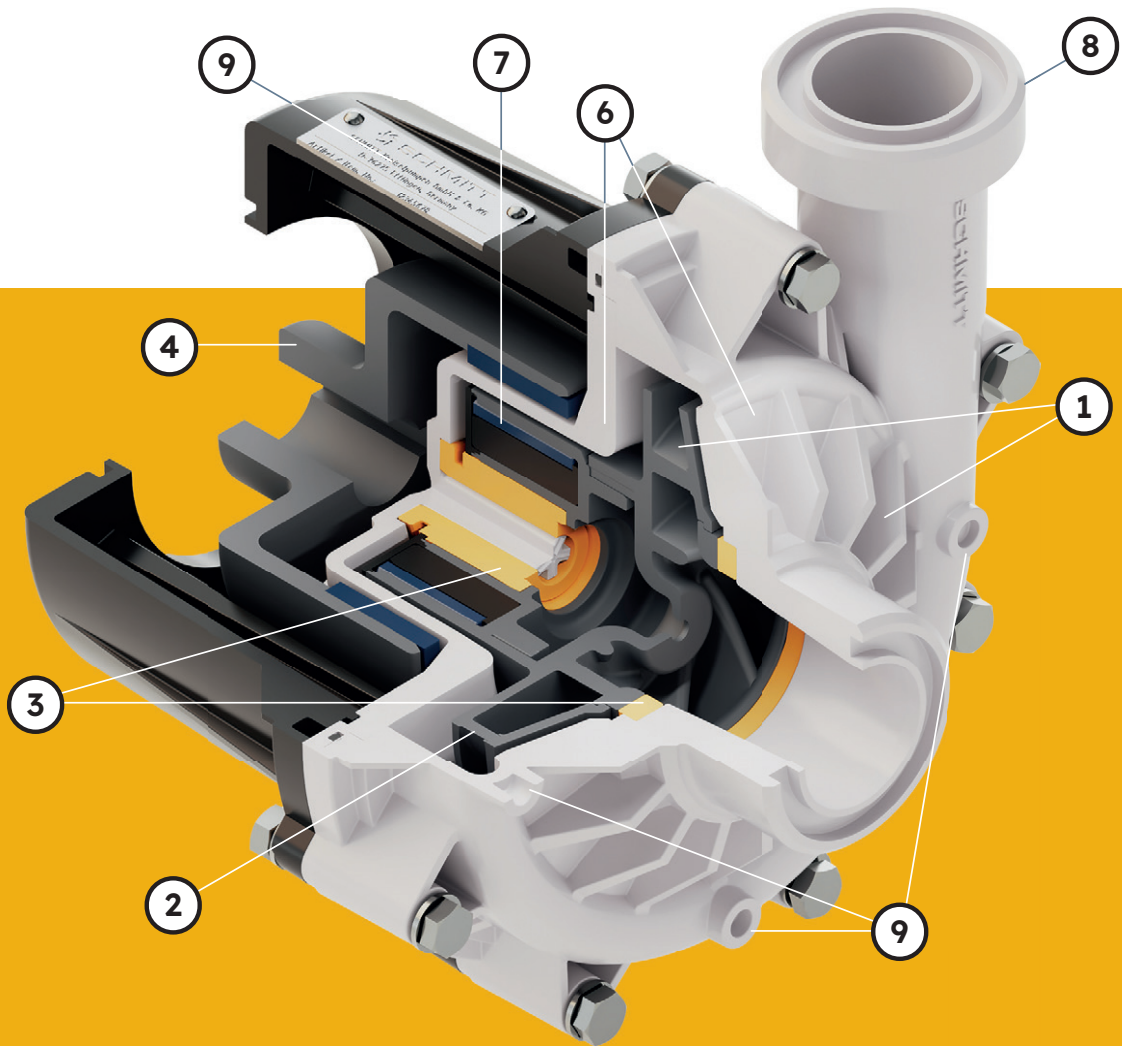

flow
reinvented!

- 1** Optimised pump hydraulics for best-in-class efficiencies of up to 76 %
- 2** Modular impeller design for easy replacement and cost-effective maintenance
- 3** Advanced slide bearing solution made from high-performance materials—durable and low-maintenance even under extreme operating conditions
- 4** Lantern bracket made of chemically resistant, carbon fiber-reinforced composite for high strength and corrosion resistance, even in aggressive environments
- 5** Chemically resistant type plate for reliable identification, even after years of operation in harsh environments
- 6** Simulation-optimized pump casing for reliable performance at high pressures and temperatures
- 7** High-performance neodymium magnets for secure torque transmission, even with high-density media
- 8** Available with threaded or flanged connections
- 9** Optional drain and vent ports for flexible installation configurations

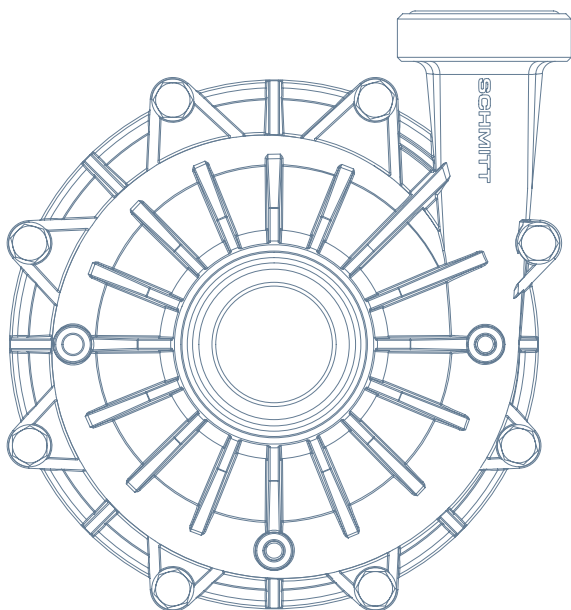

SCHMITT

Reinventing flow. Since 1964

NHM

Normal-Priming Centrifugal Pumps
Made of PVDF or PP with Magnetic Coupling



SCHMITT

Reinventing flow. Since 1964

MPN

Normal-Priming Centrifugal Pumps
Made of PVDF or PP with Magnetic Coupling



SCHMITT

Reinventing flow. Since 1964

U

Normal-Priming Centrifugal Pumps
Made of PVDF or PP with Single Mechanical Seal



SCHMITT

T

Sealless Vertical Centrifugal Pumps
Made of PVDF or PP Dry-Run Safe



Reinventing flow. Since 1964

SCHMITT

UP | UP-DO

Normal-Priming Centrifugal Pumps
Made of Stainless Steel with Single or Double Mechanical Seal

Reinventing flow. Since 1964



SCHMITT

Reinventing flow. Since 1964

SMP

Self-Priming Centrifugal Pumps
Made of PP with Magnetic Coupling



SCHMITT

Reinventing flow. Since 1964

P

Normal-Priming Turbine Pumps
Made of PVDF or PP with Magnetic Coupling



SCHMITT

NEOCHEM BASE

Standardized Chemical Pumps
ETFE-lined with Magnetic Coupling



Reinventing flow. Since 1964

SCHMITT

NEOCHEM CORE

Heavy-Duty Standardized Chemical Pumps
FFA-lined with Magnetic Coupling



Reinventing flow. Since 1964

SCHMITT-Kreiselpumpen GmbH & Co. KG
Einsteinstrasse 33
76275 Ettlingen, Germany
T +49 7243 5453-0
F +49 7243 5453-22
sales@schmitt-pumpen.de
schmitt-pumpen.de